

element II

Owner's Manual

TUSA QUALITY



T U S A

DIVE COMPUTER

LIMITED TWO-YEAR WARRANTY

For details, refer to the Product Warranty Registration Card provided.

COPYRIGHT NOTICE

This manual is copyrighted, all rights are reserved. It may not, in whole or in part, be copied, photocopied, reproduced, translated, or reduced to any electronic medium or machine readable form without prior consent in writing from Tabata USA, Inc. and Tabata Corp. Ltd. / 2002 Design.

Element II Owner's Manual, Doc. No. 12-2980

©2002 Design, 2009

San Leandro, CA USA 94577

TRADEMARK NOTICE

TUSA, the TUSA logo, Element II, and the Element II logo, are all registered and unregistered trademarks of Tabata USA and Tabata Corp. Ltd. All rights are reserved.

PATENT NOTICE

U.S. Patents have been issued, or applied for, to protect the following design features:

Data Sensing and Processing Device (U.S. Patent no. 4,882,678), Ascent Rate Indicator (U.S. Patent no. 5,156,055).

CE

The CE mark is used to mark conformity with the European Union EMC directive 89/336/EEC. TUSA dive instruments fulfill the required EU directives.

EN 13319 "Diving accessories - Depth gauges and combined depth and time measuring devices - Functional and safety requirements, test methods" is a European diving depth gauge standard. The Element II is designed to comply with this standard.

DECOMPRESSION MODEL

The program within the Element II simulates the absorption of nitrogen into the body by using a mathematical model. This model is merely a way to apply a limited set of data to a large range of experiences. The Element II dive computer model is based upon the latest research and experiments in decompression theory. **Still, using the Element II, just as using the Navy (or other) No Decompression Tables, is no guarantee of avoiding decompression sickness, i.e. "the bends."** Every diver's physiology is different, and can even vary from day to day. No machine can predict how your body will react to a particular dive profile.

CONTENTS

| | |
|--|----|
| WARRANTY, NOTICES, DECOMPRESSION MODEL | 2 |
| OVERVIEW | 7 |
| FULL LCD | 8 |
| CONTROL BUTTONS | 9 |
| OPERATING MODES | 10 |
| AUDIBLE ALARM | 10 |
| BACKLIGHT | 12 |
| POWER SUPPLY | 13 |
| PC INTERFACE | 14 |
| FEATURES AND DISPLAYS | 15 |
| BAR GRAPHS | 16 |
| ALPHA / NUMERIC DISPLAYS | 18 |
| SURFACE MODES | 21 |
| OPERATING MODES AND SURFACE MODE | 22 |
| NORM SURF MAIN | 23 |
| NORM SURF ALT | 24 |
| NORM/GAUGE SET MODES | 24 |
| Setting FO2 for Nitrox Dives | 25 |
| SET F GROUP (FO2) | 26 |
| Set FO2 GAS 1 | 27 |
| Set FO2 GAS 2 | 28 |
| Set FO2 50% Default | 29 |

CONTENTS (continued)

| | |
|---|-----------|
| SET A GROUP (NORM/GAUG ALARMS) | 29 |
| Set Audible Alarm | 29 |
| Set Depth Alarm | 30 |
| Set EDT (Elapsed Dive Time) Alarm | 31 |
| Set NiBG (Tissue Loading Bar Graph) Alarm | 32 |
| Set DTR (Dive Time Remaining) Alarm | 32 |
| Set PO2 Alarm | 33 |
| SET U GROUP (UTILITIES) | 34 |
| Set Wet Activation | 34 |
| Set Units of Measure | 35 |
| Set Deep Stop | 35 |
| Set Safety Stop | 36 |
| Set Conservative Factor | 36 |
| Set Backlight Duration | 37 |
| Set Sampling Rate | 38 |
| SET T GROUP (TIME/DATE) | 38 |
| Set Date Format | 39 |
| Set Time Format | 39 |
| Set Time | 40 |
| Set Date | 40 |
| SERIAL NUMBER | 42 |
| NORM PLAN MODE | 43 |
| FLY MODE | 45 |
| DESAT MODE | 46 |
| NORM/GAUG LOG MODE | 47 |
| HISTORY MODE | 50 |

CONTENTS (continued)

| | |
|--|-----------|
| NORM DIVE MODES | 53 |
| NO DECO DIVE TIME REMAINING (NDC) | 54 |
| OXYGEN ACCUMULATION | 55 |
| ASCENT RATE INDICATOR (ASC) | 55 |
| NORM NO DECO DIVE MODE | 56 |
| No Deco Deep Stop | 58 |
| No Deco Safety Stop | 60 |
| CAUTIONARY MODES | 61 |
| DECOMPRESSION | 62 |
| CONDITIONAL VIOLATION | 64 |
| DELAYED VIOLATION 1 | 65 |
| DELAYED VIOLATION 2 | 66 |
| DELAYED VIOLATION 3 | 67 |
| VIOLATION GAUGE MODE | 68 |
| HIGH PO2 | 70 |
| HIGH O2 | 71 |
| SWITCHING GAS MIXES | 73 |
| NORM POST DIVE MODES | 77 |
| FIRST 10 MINUTES ON SURFACE | 78 |
| AFTER 10 MINUTES ON SURFACE | 79 |
| UPLOADING SETTINGS AND DOWNLOADING DATA | 80 |
| GAUGE OPERATING MODE | 81 |
| DIGITAL GAUGE MODE | 82 |

CONTENTS (continued)

| | |
|---|-----|
| FREE DIVE OPERATING MODE | 85 |
| FREE COUNTDOWN TIMER (CDT) | 88 |
| FREE ELAPSED DIVE TIME (EDT) ALARM | 90 |
| FREE DEPTH ALARMS (DAs) | 91 |
| | |
| FREE DIVE MAIN AND ALTs | 93 |
| FREE DIVE ALARMS | 94 |
| | |
| GENERAL | 99 |
| CARE AND CLEANING | 100 |
| INSPECTIONS AND SERVICE | 100 |
| | |
| MODULE REMOVAL FROM BOOT | 101 |
| BATTERY REPLACEMENT | 101 |
| RETURNING MODULE TO BOOT | 105 |
| | |
| ALTITUDE SENSING AND ADJUSTMENT | 106 |
| CHARTS OF NO DECOMPRESSION LIMITS AT ALTITUDE | 107 |
| CHART OF OXYGEN EXPOSURE LIMITS | 108 |
| SPECIFICATIONS | 109 |
| TUSA INTERNATIONAL | 114 |
| INSPECTION/ SERVICE RECORD | 115 |

OVERVIEW

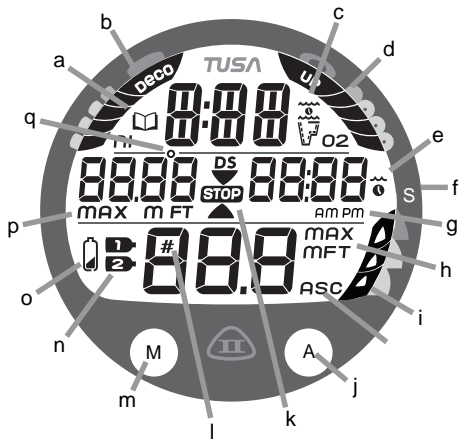

Components:

- a. Icon - Log Mode
- b. NiBG (Nitrogen Bar Graph)
- c. Icon - operating mode
 - Surface Interval
 - Plan NDC Time
 - No Deco Time Remaining
 - Deco Total Ascent Time
- d. O2BG (O2 Bar Graph)
- e. Icon - Stop Time Required
 - Elapsed Dive Time
- f. Select (S) Button
- g. Icon - Time of Day
- h. Icon - Depth/Max Depth
- i. ASC (Ascent Rate Indicator)
- j. Advance (A) Button
- k. Icon - Descend Arrow
 - Icon - Stop Bar
 - Icon - Ascend Arrow
- l. Icon - Dive #
- m. Mode (M) Button
- n. Icon - Gas # (mix)
- o. Icon - Low Battery
- p. Icon - Max/Depth
- q. Icon - Degrees

FULL LCD

INTRODUCTION

Welcome to TUSA and thank you for choosing the Element II !

It is extremely important that you read this Owner's Manual in sequence and understand it completely before attempting to use the Element II as a dive computer.

Remember that technology is no substitute for common sense, and a dive computer only provides the person using it with data, not the knowledge to use it.

CONTROL BUTTONS

The Element II features three Control Buttons that allow you to select mode options and access specific information. They are also used to enter Settings, activate the Backlight, and acknowledge the Audible Alarm.

Throughout this manual they will be referred to as the M, A, and S buttons.

- Front/Left - Mode (M) button
- Front/Right - Advance (A) button
- Right/Side - Select (S) button

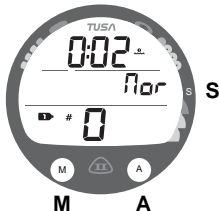



Fig. 1A - NORM MODE

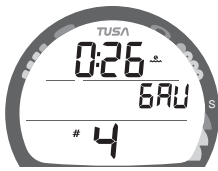

Fig. 1B - GAUG MODE

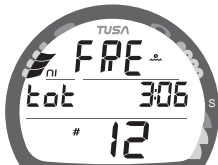

Fig. 2 - FREE MODE

OPERATING MODES

The Element II features 3 Operating Modes, NORM (Fig. 1A) which is used for Air and Nitrox SCUBA dives, GAUG (Fig. 1B) used for SCUBA dives in which Nitrogen-Oxygen calculations are not performed, and FREE (Fig. 2) used for activities that do not use SCUBA.

- > NORM Mode allows access to Fly, Desat, Log, and History Modes, as well as entering settings.
- > GAUG Mode is similar without access to Desat Mode.
- > FREE Mode only allows access to specific Free Modes.

AUDIBLE ALARM

Most warning situations that activate the Audible Alarm while operating in NORM or GAUG Mode cause the Element II to emit 1 beep per second for 10 seconds, or until the situation is corrected, or it is acknowledged by momentarily pressing and releasing the S button (less than 2 seconds).

After being acknowledged and the situation corrected, the Alarm will sound again upon reentry into the warning situation, or entry into another type of warning situation.

FREE Dive Mode has its own set of Alarms which emit 3 short beeps either 1 or 3 times which cannot be acknowledged or set Off.

Situations that will activate the NORM/GAUG 10 second Alarm include -

- Descent deeper than the Max Depth Set Point selected.
- Dive Time Remaining at the Set Point selected.
- Elapsed Dive Time at the Set Point selected.
- High PO₂ of 1.60 ATA or the Set Point selected.
- High O₂ of 300 OTU (single or daily exposure).
- Nitrogen Bar Graph at the segment Set Point selected.
- NORM/GAUG Ascent Rate exceeds 60 FPM (18 MPM) when deeper than 60 FT (18 M), or 30 FPM (9 MPM) at 60 FT (18 M) and shallower.
- Entry into Decompression Mode (Deco).
- Conditional Violation (above a required Deco Stop Depth for less than 5 minutes).
- Delayed Violation (above a required Deco Stop Depth for more than 5 minutes).
- Delayed Violation (a Deco Stop Depth greater than 60 FT/18 M is required).
- Delayed Violation (the Maximum Operating Depth of 330 FT/100 M in NORM, or 399 FT/120 M in GAUG, is exceeded).
- A Gas Switch would expose the diver to PO₂ greater than 1.60 ATA.

A single short beep (which cannot be disabled) is emitted for the following -

- Upon completion of a battery change.
- Change from Delayed to Full Violation 5 minutes after the dive.

3 short beeps (which cannot be disabled) are emitted for the following -

- NORM/GAUG Ascent Rate is 51 to 60 FPM (15.1 to 18 MPM) when deeper than 60 FT (18 M), or 26 to 30 FPM (7.5 to 9 MPM) at 60 FT (18 M) and shallower.
- FREE Dive Elapsed Dive Time Alarm (3 beeps every 30 seconds if set On).
- FREE Dive Depth Alarms 1/2/3 (set sequentially deeper) - each 3 beeps 3 times.

- FREE Dive NiBG Alarm (Caution zone, 4 segments) - 3 beeps 3 times.
- Entry into Deco during a FREE Dive (Permanent Violation) - 3 beeps 3 times.
- Free Dive Mode Countdown Timer reaches 0:00 - each 3 beeps 3 times.

During the following NORM Dive situations, the 10 second continuous tone will be followed by a 5 second steady beep that will not turn off when acknowledged -

- Ascending above a required Decompression Stop Depth for more than 5 minutes (referred to as a Delayed Violation).
- Decompression requires a Stop Depth of 70 FT/21 M or deeper.
- Being on the Surface for 5 minutes after a Conditional Violation (Permanent Violation).

BACKLIGHT

- > To activate the Backlight, while on the surface and during dives >> depress the S button for 2 seconds.
- The Backlight will illuminate the display for button depression time plus the Duration time set 0, 5, or 10 seconds.
(*The Backlight will turn Off if the button is held depressed for more than 10 seconds.)
- Press the button again to activate as desired.

△ NOTE: Extensive use of the Backlight reduces estimated Battery life. Also, the Backlight does not operate during a Low Battery Condition or when the Element II is connected to a PC.

POWER SUPPLY

The Element II uses (1) 3 volt CR2450 Lithium Battery which should maintain operation for 1 year or 300 dive hours if 2 dives are conducted during each dive period. The Element II checks battery voltage every 2 minutes while on the surface.

- If voltage of the Element II decreases to the Warning level (2.75 volts), the Battery icon will appear on Surface display screens (Fig. 3a) as an indication that the Battery should be changed prior to commencing a series of dives.
- If voltage decreases to the Alarm level (2.50 volts), the Battery icon and graphic BAT will flash for 5 seconds then the unit will shut Off.
- Low Battery conditions are not displayed during dives. If a Low Battery condition was not displayed prior to starting a Dive, and a Low Battery Condition occurs during the dive, there will be sufficient Battery power remaining to maintain operation for the remainder of that dive.
- Upon surfacing, the Low Battery icon will be displayed. If voltage was at the Alarm level (2.50 volts), the graphics CHG and BAT will alternate for 5 seconds (Fig. 4a) followed by shut down of the unit until the Battery is changed.

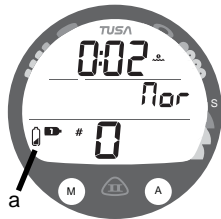

Fig. 3 - LOW BATTERY

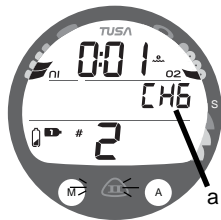

Fig. 4 - LOW BATTERY ALARM (during dive)

PC INTERFACE

Interface with a PC (for data Upload and Download) is accomplished by connecting the Element II to a PC USB Port using the USB Interface Cable available as an optional accessory.

The PC Interface program, together with a USB Driver, is downloadable from tusa.com. The Help portion serves as the user manual and can be printed for personal use. The Settings Upload portion is used to check the Element II's existing Settings and for entering Time, Alarm, and other settings into the Element II. The Download portion is used to retrieve Data that was sampled during dives and stored in the Element II's memory.

The Element II checks for an External Access request once every second while in Surface Mode. Checks are not made if the unit is wet. For a connection to be made, the Interface Cable is clipped onto the Element II's Data Port and plugged into a PC USB Port. To establish the connection, the PC program must be running.

When the connection is made, a PC screen appears on the Element II displaying the graphic PC and a countdown for 2 minutes or until completion of the interface operation. Then operation reverts to the Surface Main screen.

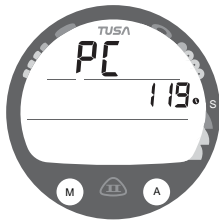

Fig. 5 - PC
(during upload/download)

FEATURES AND DISPLAYS

BAR GRAPHS

The Element II features 3 Bar Graphs >> NiBG, O2BG, and ASC.

NiBG (Nitrogen Loading Bar Graph)

The NiBG (Fig. 6a) represents tissue loading of nitrogen, showing your relative no decompression or decompression status. As your depth and elapsed dive time increase, segments will add to the NiBG, and as you ascend to shallower depths, the segments will recede, indicating that additional no decompression time is allowed for multilevel diving.

The NiBG monitors 12 different nitrogen compartments simultaneously and displays the one that is in control of your dive. It is divided into a No Decompression (normal) zone, a Caution zone (also No Deco), and a Decompression (danger) zone.

While you cannot provide a guarantee against the occurrence of decompression sickness, you may choose your own personal zone of caution based upon age, physique, excessive weight, etc., to reduce the statistical risk.



NOTE: Displays associated with oxygen and the O2BG will only appear if FO2 has been set at a value other than 'Air' (e.g., a numerical value).

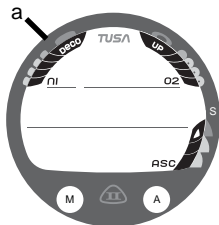

Fig. 6 - NiBG

Oxygen Bar Graph (O2BG)

The O2BG (Fig. 7a) represents oxygen accumulation, showing the maximum of either per dive accumulated oxygen, or 24 hour period accumulated oxygen.

As your oxygen exposure (accumulation) increases during the dive, segments will add to the O2BG, and as saturation decreases, it will begin to recede, indicating that additional exposure is allowed for that dive and 24 hour period.

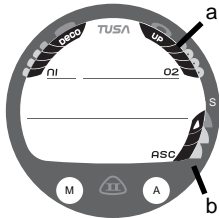

Fig. 7 - O2BG & ASC

Ascent Rate Indicator (ASC)

The ASC (Fig. 7b) provides a visual representation of ascent speed (i.e., an ascent speedometer).

The segments of the ASC represent two sets of speeds which change at a reference Depth of 60 FT (18 M). Refer to the chart for segment values.



WARNING: At depths greater than 60 FT (18 M), ascent rates should not exceed 60 feet per minute (18 meters per minute). At depths of 60 FT (18 M) and shallower, ascent rates should not exceed 30 feet per minute (9 meters per minute).

| ASC values | | |
|-------------------------------------|---------------|---------|
| Deeper than 60 FT (18 M) | | |
| Segments | Ascent Rate = | |
| Displayed | FPM | MPM |
| 0 | 0 - 20 | 0 - 6 |
| 1 | 21-50 | 6.5-15 |
| 2 | 51-60 | 15.5-18 |
| 3 | >60 | >18 |
| 60 FT (18 M) & Shallower | | |
| Segments | Ascent Rate = | |
| Displayed | FPM | MPM |
| 0 | 0 - 10 | 0 - 3 |
| 1 | 11-25 | 3.5-7.5 |
| 2 | 26-30 | 8-9 |
| 3 | >30 | >9 |



Fig. 8 - DIVE MAIN

ALPHA/NUMERIC DISPLAYS

Each numeric and graphic display represents a unique piece of information. It is imperative that you understand the formats, ranges, and values of the information represented to avoid any possible misunderstanding that could result in error.

Depth

Current Depth is displayed on the Main Dive screens (Fig. 8a) with the FT (or M) icon from 0 to 330 FT (99.9 M) in NORM/FREE, 399 FT (120 M) in GAUG, in increments of 1 FT (.1 M).

Stop Depths (Deep, Safety, and Deco) are also displayed on the Main screens (Fig. 8b) when applicable.

Max Depth is displayed on Alternate screens (Fig. 9a) with the MAX and FT (or M) icons from 0 to 330 FT (99.9 M) in NORM/FREE, 399 FT (120 M) in GAUG, in increments of 1 FT (.1 M).

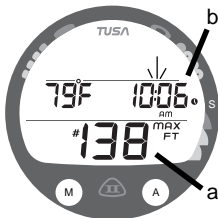

Fig. 9 - DIVE ALTERNATE

Time and Date

Most Time displays like Time of Day (Fig. 9b) are shown in hour:minute format (i.e., 9:46 represents 9 hours and 46 minutes, not 946 minutes!). The colon that separates hr:min (min;sec) blinks once per second when the display is indicating real time (e.g., Time of Day, Elapsed Dive Time).

When Times are calculated projections such as NDC and Elapsed Dive Time (Fig. 10a/b), the colon is solid (non blinking).

FREE Dive Mode displays Times in minute:second format.

Date is only displayed in Log Mode.

Temperature

Temperature can be viewed by accessing an Alternate Display while on the surface and during dives (Fig. 11a).

Altitude

When above the sea level range, which extends up to 3,000 feet (915 meters) elevation, Altitude can be viewed on Surface Alternate screens as EL (Elevation Level) from 2 up to 7 (Fig. 11b).

- EL2 = 3,001 to 5,000 feet (916 to 1,525 meters)
- EL3 = 5,001 to 7,000 feet (1,526 to 2,135 meters)
- EL4 = 7,001 to 9,000 feet (2,136 to 2,745 meters)
- EL5 = 9,001 to 11,000 feet (2,746 to 3,355 meters)
- EL6 = 11,001 to 13,000 feet (3,356 to 3,965 meters)
- EL7 = 13,001 to 14,000 feet (3,966 to 4,270 meters)

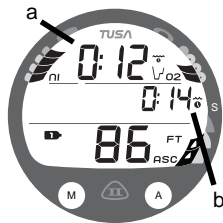

Fig. 10 - TIMES (DIVE)

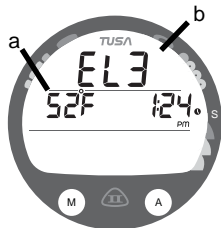

Fig. 11 - ELEV & TEMP



WARNINGS AND SAFETY RECOMMENDATIONS

- **It should not be considered that the capabilities built into the Element II provide an implied approval or consent from TUSA for individuals to exceed the defined limits for recreational diving, as agreed on by all internationally recognized training agencies.**
- **The oxygen features of the Element II are intended for use by recreational divers trained for Nitrox diving by an instructor certified by a recognized training agency to teach diving with Nitrox.**
- **Conducting repetitive dives using enriched nitrogen-oxygen mixtures can lead to oxygen buildup, reducing oxygen tolerance while increasing the risk of pulmonary oxygen toxicity.**
- **The Element II provides information based upon a personal dive profile, and therefore must not be shared between divers. It is impossible for two divers to stay precisely together underwater, and your computer's dive profile tracking of previous dives will be pertinent to you only. Nitrogen and oxygen loading of a second user may be significantly different and swapping dive computers could lead to inaccurate and dangerous predictions of decompression and oxygen accumulation status.**

SURFACE MODES

OPERATING MODES

As described previously, there are 3 Operating Modes -

- NORM - for Air or Nitrox SCUBA dives
- GAUG - for SCUBA dives with no Nitrogen/Oxygen calculations
- FREE - for breath hold dives with no SCUBA

SURFACE MODE

After activation and while the default Surface Main screen is displayed, depressing the M button repeatedly (2 sec each time) steps through the operating mode Surface Main screens.

- The operating mode selected (NORM, GAUG, or FREE) will remain on display for 2 hours until a dive is made or another operating mode is selected.

If a dive has been conducted within the past 24 hours, the SURF MAIN screen for that mode will be displayed until changed.

At any time while operating in Surface Modes, the Element II will enter Dive Mode upon descent to 5 FT (1.5 M) for 5 seconds.

The Element II will enter post dive Surface Mode following a dive upon ascent to 4 FT (1.2 M) for 1 second. The Surface Interval Time colon will flash during the first 10 minutes after a NORM/GAUG dive, or first 1 minute after a FREE dive.

During the first 2 hours after a dive, the SURF MAIN screen (NORM, GAUG, or FREE) remains on display.

NORM SURF MAIN, information includes (Fig. 12):

- > Surface Interval Time (hr:min) with clock/wave icon
- > Graphic Nor
- > Tank 1 icon representing Gas 1, which is the default start Gas and default Gas 10 minutes after a dive
- > Number of that dive (0 if no dive has been made yet) with # icon
- > Battery icon if a Low Battery Condition exists
- > NiBG, if any after a NORM or FREE dive
- > O2BG, if any after a NORM Nitrox dive

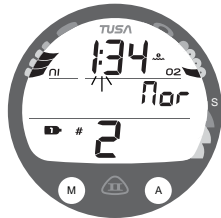

Fig. 12 - SURFACE MAIN
(after dive 2)

- Depressing the A button for 2 seconds will access the NORM SURF ALT screen for 5 seconds.
- Pressing and releasing the A button (< 2 sec) will access Log Mode, then pressing it again will access History Mode.
- Pressing and releasing the S button (< 2 sec) will access Plan Mode, then pressing it again after dives will access the Time to Fly screen, then again the Dsat Time screen.
- Depressing the S button for 2 seconds will activate the Backlight.
- Depressing both the A and S buttons simultaneously for 2 seconds will access the Set Menu.
- Depressing the M button for 2 seconds will access the GAUG Surface Main screen, then another 2 second press will access the FREE Surface Main screen.



Fig. 13 - NORM SURF ALT

NORM SURF ALT, information includes (Fig. 13):

- > Altitude graphic (EL2 to EL7), if above 3000 feet (915 meters) elevation, blank if below.
 - > Temperature with degrees icon and graphic F (or C)
 - > Time of Day (hr:min) with Time (clock) and AM (or PM) icons.
-
- After 5 seconds, or pressing/releasing the A button (< 2 sec) will revert to the NORM Surface Main screen.
 - Depressing the S button will activate the Backlight.

NORM/GAUGE SET MODES

SURF MAIN >> SET F >> SET A >> SET U >> SET T >> SN

Access and step through of the sequence is gained by repeated simultaneous 2 second presses of the A and S buttons.

Alarm (Set A), Utility (Set U), and Time (Set T) Set Points can also be set/changed using the PC Interface program.

- FO2 (Set F) entries must be made using the push buttons.

While operating in the set menus, the Backlight will not operate when the S button is pressed to change settings.

SETTING FO2 FOR NITROX DIVES

- For each value of FO2, the MOD (Max Operating Depth) that can be achieved for the PO2 Alarm limit previously set will be displayed.
- When the FO2 50% Default is set On and FO2 Gas 1 is set for a numerical value, 10 minutes on the surface after that dive, the FO2 for Gas 1 will be displayed as 50 and further dives will be calculated based on 50% O2 for oxygen calculations and 21% O2 for Nitrogen calculations (79% Nitrogen) unless the FO2 for Gas 1 is set before the dive.
- FO2 for Gas 1 continues to reset to the FO2 50% Default after subsequent repetitive dives until 24 hours elapse after the last dive, or the FO2 50% Default is turned Off.
- When the FO2 50% Default is set Off, the FO2 for Gas 1 will remain at the last Set Point for the remainder of that series of repetitive dives.
- The default FO2 for Gas 1 each new dive period is Air.
- When FO2 for Gas 1 is set for AIR, the calculations are the same as when it is set to an FO2 of 21%. When FO2 for Gas 1 is set to Air, it remains set for Air until it is set for a numerical FO2 value (21 to 50%).
- When FO2 is set only to Air, the O2BG and PO2 values and/or warnings will not be displayed during the dive.
- MODs affected by the PO2 limit set will not be displayed when FO2 for Gas 1 is set to Air.
- The Element II keeps track of O2 so that if FO2 for Gas 1 is subsequently set for a numerical value, the O2 accumulated during previous Air dives will be accounted for in the next Nitrox dive (during that dive period and series of repetitive dives).
- Once FO2 Gas 1 is set for a numerical value (21 to 50%) and a dive is made, the Air option is disabled until 24 hours elapse after the last dive. The Air option will not be displayed in Set FO2 Gas 1 until a full 24 hour Surface Interval has elapsed.

- If FO2 for Gas 1 is set for 21%, it will remain set for 21% for that series of dives until set for a higher numerical value.
- If the FO2 50% Default is set Off, FO2 for Gas 2 will remain at it's Set Point previously selected until it is changed. If the FO2 50% Default is set On, FO2 for Gas 2 will Default to 50% after the dive.
- The Element II is programmed to prevent FO2 for Gas 2 from being set at values lower than the FO2 Set Point for Gas 1. Gas 2 can only be set to values equal to or higher than the FO2 Set Points of Gas 1.
- When setting FO2 for Gas 2, the lowest value available will be the FO2 Set Point of Gas 1. If FO2 Gas 1 is set for 32%, FO2 Gas 2 can only be set at values from 32 to 100%.
- FREE Dive Mode nitrogen calculations are only based on AIR and not affected by these FO2 Settings.

SET F GROUP (FO2)

Set F >> FO2 Gas 1 >> FO2 Gas 2 >> FO2 50% Default.

- > Depressing the A and S buttons simultaneously for 2 seconds while the NORM (or GAUG) Surface Main screen is displayed will access the Set F screen (Fig. 14).
- > Pressing and releasing the A button momentarily (< 2 sec) while SET F is displayed will access Set FO2 Gas 1.

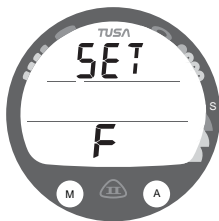

Fig. 14 - SET F (FO2)

Set FO2 Gas 1, information includes (Fig. 15A/B):

- > Graphic FO2
- > Max Depth allowed for the PO2 Alarm set with MAX and FT (or M) icons and graphic PO2, blank if Air
- > Tank 1 icon representing Gas (mix) 1
- > FO2 Set Point, flashing

- Depressing the S button will scroll upward through the Set Points from Air to 21 through 50% in 1% increments, at a rate of 8 Set Points per second.
- > The scroll will stop when the button is released, or momentarily at 32% (even if the button is held depressed).
- Depressing the S button will resume the scroll from 32 through 50%, then stop at Air (or 21%).
- Pressing and releasing the S button momentarily and repeatedly (< 2 sec each time) will step upward through the Set Points one at a time.
- Pressing and releasing the A button momentarily (< 2 sec) will save the setting and access Set FO2 Gas 2.
- Depressing the A and S buttons simultaneously for 2 seconds will save the setting and revert to the SET F screen.
- Depressing the M button for 2 seconds, or if no button is pressed for a period of 2 minutes, operation will revert to the NORM (or GAUG) Surface Main screen.

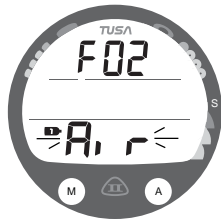

Fig. 15A - SET FO2 GAS 1
(Air setting)

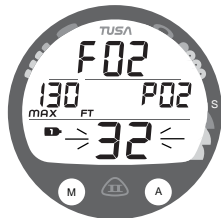

Fig. 15B - SET FO2 GAS 1
(32% Nitrox setting)

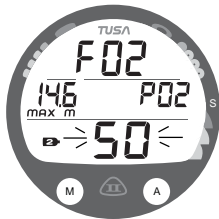

Fig. 16A - SET FO2 GAS 2
(50% Nitrox setting)

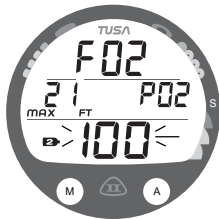

Fig. 16B - SET FO2 GAS 2
(100% Nitrox setting)

Set FO2 Gas 2, information includes (Fig. 16A/B):

- > Graphic FO2
 - > Max Depth allowed for the PO2 Alarm set with MAX and FT (or M) icons and graphic PO2, blank if Air
 - > Tank 2 icon representing Gas (mix) 2
 - > FO2 Set Point, flashing
- Depressing the S button will scroll upward through the Set Points in 1% increments, at a rate of 8 per second.
 - The scroll will start at the FO2 Gas 1 Set Point and stop when the button is released, or momentarily at 50%, then 80% (even if the button is held depressed).
 - Depressing the S button will resume the scroll through 100%, then stop at the Gas 1 setting.
 - Pressing and releasing the S button momentarily and repeatedly (< 2 sec each time) will step upward through the Set Points one at a time.
 - Pressing and releasing the A button momentarily (< 2 sec) will save the setting and access Set FO2 50% Default.
 - Depressing the A and S buttons simultaneously for 2 seconds will save the setting and revert to the Set F screen.
 - Depressing the M button for 2 seconds, or if no button is pressed for a period of 2 minutes, operation will revert to the NORM (or GAUG) Surface Main screen.

Set FO2 50% Default, information includes (Fig. 17):

- > Graphics FO2, dFLt, and 50
 - > Set Point graphic OFF (or ON), flashing.
- Pressing and releasing the S button momentarily (< 2 sec) will toggle between OFF and ON.
 - Pressing and releasing the A button momentarily (< 2 sec) will save the setting and revert to the Set F screen.
 - Depressing the M button for 2 seconds, or if no button is pressed for a period of 2 minutes, operation will revert to the NORM (or GAUG) Surface Main screen.

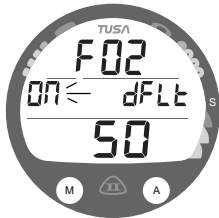

Fig. 17 - SET FO2 DEFAULT

SET A GROUP

Set A >> Audible >> Depth >> EDT >> NiBG >> DTR >> PO2.

- > Depressing the A and S buttons simultaneously for 4 seconds while the NORM (or GAUG) Surface Main screen is displayed will access the Set A screen (Fig. 18).
- > Pressing and releasing the A button momentarily (< 2 sec) while SET A is displayed will access Set Audible Alarm.

SET AUDIBLE ALARM

This option allows the Audible Alarm to be disabled. Due to their importance, some cautionary situations will cause the Audible alarm to sound even if this feature is set to OFF.

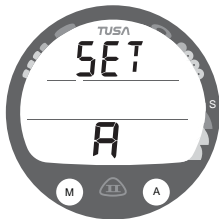

Fig. 18 - SET A (Alarms)

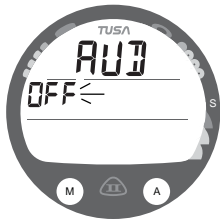

Fig. 19 - SET AUDIBLE AL

Set Audible Alarm, information includes (Fig. 19):

- > Graphic AUD
- > Set Point graphic ON (or OFF), flashing.
- Pressing and releasing the S button momentarily (< 2 sec) will toggle between ON and OFF.
- Pressing and releasing the A button momentarily (< 2 sec) will save the setting and access Set Depth Alarm.
- Depressing the A and S buttons simultaneously for 2 seconds will save the setting and revert to the Set A screen.
- Depressing the M button for 2 seconds, or if no button is pressed for a period of 2 minutes, operation will revert to the NORM (or GAUG) Surface Main screen.

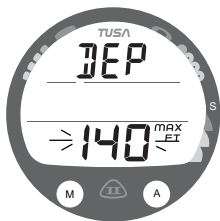

Fig. 20 - SET DEPTH AL

Set Depth Alarm, information includes (Fig. 20):

- > Graphic DEP
- > Set Point value, flashing, with MAX and FT (or M) icons.
- Depressing the S button will scroll upward through the Set Points from 30 to 330 FT (10 to 100 M) in 10 FT (1 M) increments at a rate of 8 per second until it is released.
- Pressing and releasing the S button momentarily and repeatedly (< 2 sec each time) will step upward through the Set Points one at a time.
- Pressing and releasing the A button momentarily (< 2 sec) will save the setting and access Set EDT Alarm.

- Depressing the A and S buttons simultaneously for 2 seconds will save the setting and revert to the Set A screen.
- Depressing the M button for 2 seconds, or if no button is pressed for a period of 2 minutes, operation will revert to the NORM (or GAUG) Surface Main screen.

FREE Mode has separate Depth and EDT alarms.

SET EDT ALARM, information includes (Fig. 21):

- > Graphic EDT (meaning Elapsed Dive Time).
 - > Set Point value (hr:min), flashing, with wave/clock icons.
- Depressing the S button will scroll upward through the Set Points from 0:10 to 3:00 (hr:min) in 5 minute (:05) increments at a rate of 8 per second.
 - Pressing and releasing the S button momentarily and repeatedly (< 2 sec each time) will step upward through the Set Points one at a time.
 - Pressing and releasing the A button momentarily (< 2 sec) will save the setting and access Set NiBG Alarm.
 - Depressing the A and S buttons simultaneously for 2 seconds will save the setting and revert to the Set A screen.
 - Depressing the M button for 2 seconds, or if no button is pressed for a period of 2 minutes, operation will revert to the NORM (or GAUG) Surface Main screen.

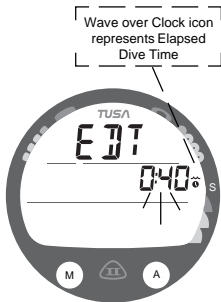

Fig. 21 - SET EDT AL

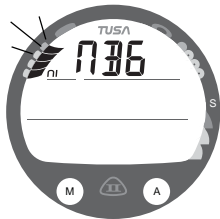

Fig. 22 - SET NIBG AL

Wave over Clock over
Profile icon represents
Dive Time Remaining

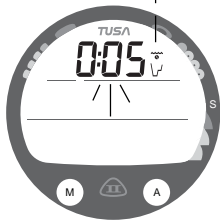

Fig. 23 - SET DTR AL

Set NiBG Alarm, information includes (Fig. 22):

- > Graphic NBG (meaning Nitrogen Bar Graph).
- > NiBG Set Point (segments) flashing, with NI icon.

- Pressing and releasing the S button momentarily and repeatedly (< 2 sec each time) will step through the Set Points from 1 to all 5 segments (Deco) one at a time.
- Pressing and releasing the A button momentarily (< 2 sec) will save the setting and access Set DTR Alarm.
- Depressing the A and S buttons simultaneously for 2 seconds will save the setting and revert to the Set A screen.
- Depressing the M button for 2 seconds, or if no button is pressed for a period of 2 minutes, operation will revert to the NORM (or GAUG) Surface Main screen.

FREE Mode has a separate NiBG Alarm.

Set DTR Alarm, information includes (Fig. 23):

- > Set Point value (hr:min), flashing, with wave/clock/profile icons.
- Depressing the S button will scroll upward through the Set Points from 0:00 to 0:20 (:min) in 1 minute (0:01) increments at a rate of 8 per second.

- Pressing and releasing the S button momentarily and repeatedly (< 2 sec each time) will step upward through the Set Points one at a time.
- Pressing and releasing the A button momentarily (< 2 sec) will save the setting and access Set PO2 Alarm.
- Depressing the A and S buttons simultaneously for 2 seconds will save the setting and revert to the Set A screen.
- Depressing the M button for 2 seconds, or if no button is pressed for a period of 2 minutes, operation will revert to the NORM (or GAUG) Surface Main screen.

Set PO2 Alarm, information includes (Fig. 24):

- > Graphics PO2 and AtA.
 - > Set Point value, flashing, with MAX icon.
- Pressing and releasing the S button momentarily and repeatedly (< 2 sec each time) will step upward through the Set Points from 1.20 to 1.60 (ATA) in .10 increments.
 - Pressing and releasing the A button momentarily (< 2 sec) will save the setting and revert to the Set A screen.
 - Depressing the M button for 2 seconds, or if no button is pressed for a period of 2 minutes, operation will revert to the NORM (or GAUG) Surface Main screen.

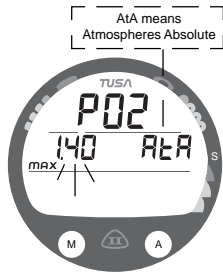

Fig. 24 - SET PO2 AL

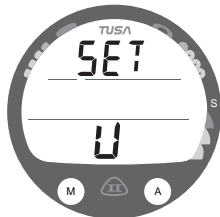

Fig. 25 - SET U (Utilities)

SET U GROUP (UTILITIES)

SET U >> Wet Activation >> Units >> Deep Stop >> Safety Stop
>> Conservative Factor >> Backlight Duration >> Sample Rate.

- > Depressing the A and S buttons simultaneously for 6 seconds while the NORM (or GAUG) Surface Main screen is displayed, will access the Set U screen (Fig. 25).
- > Pressing and releasing the A button momentarily (< 2 sec) while Set U is displayed will access Set Wet Activation.

Set Wet Activation, information includes (Fig. 26):

- > Graphics WET and ACt (meaning Activation).
 - > Set Point graphic ON (or OFF) flashing.
- Pressing and releasing the S button momentarily (< 2 sec) will toggle between ON and OFF.
 - Pressing and releasing the A button momentarily (< 2 sec) will save the setting and access Set Units.
 - Depressing the A and S buttons simultaneously for 2 seconds will save the setting and revert to the Set U screen.
 - Depressing holding the M button for 2 seconds, or if no button is pressed for a period of 2 minutes, operation will revert to the NORM (or GAUG) Surface Main screen.

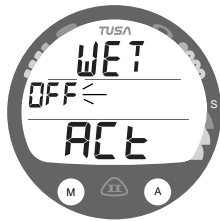

Fig. 26 - SET WET
ACTIVATION

Set Units, information includes (Fig. 27):

- > Set Point icons/graphics F and FT (or C and M), flashing.
- Pressing and releasing the S button momentarily (< 2 sec) will toggle between Imperial (F, FT) and Metric (C, M).
- Pressing and releasing the A button momentarily (< 2 sec) will save the setting and access Set Deep Stop.
- Depressing the A and S buttons simultaneously for 2 seconds will save the setting and revert to the Set U screen.
- Depressing the M button for 2 seconds, or if no button is pressed for a period of 2 minutes, operation will revert to the NORM (or GAUG) Surface Main screen.

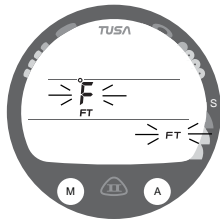

Fig. 27 - SET UNITS

Set Deep Stop, information includes (Fig. 28):

- > Graphic DS (meaning Deep Stop).
- > Set Point ON or OFF, flashing, with DS and STOP icons.
- Pressing and releasing the S button momentarily (< 2 sec) will toggle the Set Point between OFF and ON.
- Pressing and releasing the A button momentarily (< 2 sec) will save the setting and access Set Safety Stop.
- Depressing the A and S buttons simultaneously for 2 seconds will save the setting and revert to the Set U screen.
- Depressing the M button for 2 seconds, or if no button is pressed for a period of 2 minutes, operation will revert to the NORM (or GAUG) Surface Main screen.

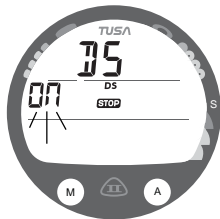

Fig. 28 - SET DEEP STOP

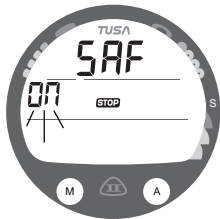

Fig. 29 - SET SAFETY STOP

Set Safety Stop, information includes (Fig. 29):

- > Graphic SAF (meaning Safety Stop).
- > Set Point ON or OFF, flashing, with STOP icon.
- Pressing and releasing the S button momentarily (< 2 sec) will toggle the Set Point between OFF and ON.
- Pressing and releasing the A button momentarily (< 2 sec) will save the setting and access Set Conservative Factor.
- Depressing the A and S buttons simultaneously for 2 seconds will save the setting and revert to the Set U screen.
- Depressing the M button for 2 seconds, or if no button is pressed for a period of 2 minutes, operation will revert to the NORM (or GAUG) Surface Main screen.

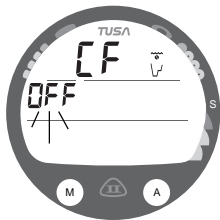

Fig. 30 - SET CONSERVATIVE FACTOR

Set Conservative Factor, information includes (Fig. 30):

- > Graphic CF (meaning Conservative Factor) with wave/clock/profile icon.
- > Set Point ON or OFF, flashing.
- Pressing and releasing the S button momentarily (< 2 sec) will toggle the Set Point between ON and OFF.
- Pressing and releasing the A button momentarily (< 2 sec) will save the setting and access Set Backlight Duration.
- Depressing the A and S buttons simultaneously for 2 seconds will save the setting and revert to the Set U screen.

- Depressing the M button for 2 seconds, or if no button is pressed for a period of 2 minutes, operation will revert to the NORM (or GAUG) Surface Main screen.

△ NOTE: When the Conservative Factor is set ON, the No Deco Limit times are reduced to values equivalent to those that would be available at the next higher 3000 foot (915 meter) Altitude.

Set Backlight Duration, information includes (Fig. 31):

- > Graphics BL and dur (meaning Backlight Duration).
 - > Set Point (seconds value), flashing, with clock icon and graphic SEC (meaning Seconds).
- Pressing and releasing the S button momentarily and repeatedly (< 2 sec each time) will step upward through the Set Points of 0, 5, and 10 (seconds).
 - Pressing and releasing the A button momentarily (< 2 sec) will save the setting and access Set Sampling Rate.
 - Depressing the A and S buttons simultaneously for 2 seconds will save the setting and revert to the Set U screen.
 - Depressing the M button for 2 seconds, or if no button is pressed for a period of 2 minutes, operation will revert to the NORM (or GAUG) Surface Main screen.

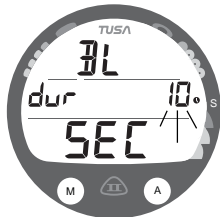

Fig. 31 - SET BACKLIGHT DURATION

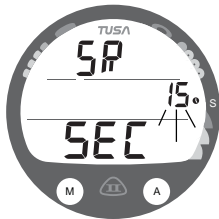

Fig. 32 - SET SAMPLING RATE

Set Sampling Rate, information includes (Fig. 32):

- > Graphic SR (meaning Sampling Rate).
- > Set Point (seconds value), flashing, with clock icon and graphic SEC (meaning Seconds).
- Pressing and releasing the S button momentarily and repeatedly (< 2 sec each time) will step upward through the Set Points of 2, 15, 30, and 60 (seconds).
- Pressing and releasing the A button momentarily (< 2 sec) will save the setting and revert to the Set U screen.
- Depressing the M button for 2 seconds, or if no button is pressed for a period of 2 minutes, operation will revert to the NORM (or GAUG) Surface Main screen.

SET T GROUP (TIME)

SET T >> Date Format >> Hour Format >> Time >> Date.

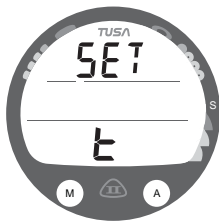

Fig. 33 - SET T (Time)

- > Depressing the A and S buttons simultaneously for 8 seconds while the NORM (or GAUG) Surface Main screen is displayed, will access the Set T screen (Fig. 33).
- > Pressing and releasing the A button momentarily (< 2 sec) while Set T is displayed will access Set Date Format.

Set Date Format, information includes (Fig. 34):

- > Set Point graphic M - D (or D - M), flashing.
 - > Graphic dAtE.
 - Pressing and releasing the S button momentarily (< 2 sec) will toggle the Set Point between M - D and D - M.
 - Pressing and releasing the A button momentarily (< 2 sec) will save the setting and access Set Hour Format.
 - Depressing the A and S buttons simultaneously for 2 seconds will save the setting and revert to the Set T screen.
-
- > M - D means Month will be displayed to the left of Day.
 - > D - M means Day will be displayed to the left of Month.



Fig. 34 - SET DATE FORMAT
(M = Month, D = Day)

Set Hour Format, information includes (Fig. 35):

- > Graphic HR (meaning Hour Format).
- > Set Point 12 (or 24), flashing.
- Pressing and releasing the S button momentarily (< 2 sec) will toggle the Set Point between 12 and 24.
- Pressing and releasing the A button momentarily (< 2 sec) will save the setting and access Set Time.
- Depressing the A and S buttons simultaneously for 2 seconds will save the setting and revert to the Set T screen.



Fig. 35 - SET HOUR
FORMAT

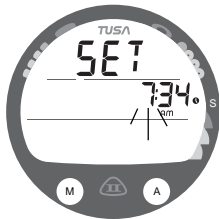

Fig. 36 - SET TIME

Set Time, information includes (Fig. 36):

- > Graphic SET.
 - > Time (hr:min) Set Point, Hour digits flashing, with Time (clock) and AM (or PM) icons if 12 Hour Format.
- Depressing the S button will scroll upward through the Hour Set Points at a rate of 8 per second until it is released.
 - Pressing and releasing the S button momentarily and repeatedly (< 2 sec each time) will step upward through the Set Points one at a time.
 - Pressing and releasing the A button momentarily (< 2 sec) will save the Hour setting the Minute digits will flash.
 - Depressing the S button will scroll upward through the Minute Set Points at a rate of 8 per second.
 - Pressing and releasing the S button momentarily and repeatedly (< 2 sec each time) will step upward through the Set Points one at a time.
 - Pressing and releasing the A button momentarily (< 2 sec) will save the Time setting and access Set Date.



Fig. 37 - SET DATE (Year)

Set Date, information includes (Fig. 37):

Upon access, the Set Date screen displays the graphic YMD (meaning Date is arranged as Year Month.Day) or YDM (meaning Date is arranged as Year Day.Month) with the Year Set Point flashing (Fig. 13).

- Depressing the S button while the Year digits are flashing will scroll upward through the Set Points at a rate of 8 per second from 2009 to 2052 (with leap year corrections).
- Pressing and releasing the S button momentarily and repeatedly (< 2 sec each time) will step upward through the Year Set Points one at a time.
- Pressing and releasing the A button momentarily (< 2 sec) will save the Year setting and the Month digits will flash, regardless of their location on the display (Fig. 38A/B).
- Depressing the S button will scroll upward through the Month Set Points at a rate of 8 per second.
- Pressing and releasing the S button momentarily and repeatedly (< 2 sec each time) will step upward through the Month Set Points one at a time.
- Pressing and releasing the A button momentarily (< 2 sec) will save the Month setting and the Day digits will flash, regardless of their location on the display.
- Depressing the S button will scroll upward through the Day Set Points at a rate of 8 per second.
- Pressing and releasing the S button momentarily and repeatedly (< 2 sec each time) will step upward through the Day Set Points one at a time.
- Pressing and releasing the A button momentarily (< 2 sec) will save the Date setting and revert to the Set T screen.

> Year will not be displayed in any mode other than Set Date.

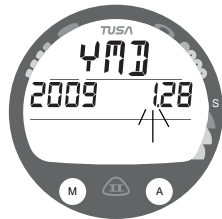

Fig. 38A - SET DATE (Month)



Fig. 38B - SET DATE (Month)



Fig. 39 - SERIAL NUMBER
(with Firmware Revision)

SERIAL NUMBER, information includes (Fig. 39):
Depressing the A and S buttons simultaneously for 10 seconds while viewing the NORM (or GAUG) Surface Main screen will access the Serial Number screen.

- > Graphic SN.
- > Factory programmed Serial Number.
- > Firmware revision number (e.g., graphic r1A or higher).

- Depressing the A and S buttons simultaneously for 2 seconds will revert to the Surface Main screen.
- Depressing the M button for 2 seconds, or if no button is pressed for a period of 2 minutes, operation will revert to the NORM (or GAUG) Surface Main screen.

△ NOTE: The Serial Number and Firmware Revision will be requested in the event that you contact TUSA regarding the Element II. Enter them in the Records section provided in the back of this manual.

Settings revert to the last ones entered/saved when 24 hours elapse without a dive or after a dive.

NORM PLAN MODE

TUSA strongly recommends that you review the Plan Mode dive times prior to every NORM dive to help you plan your dive as required to avoid exceeding no decompression or oxygen exposure limits. This is especially important for repetitive dives when Plan Mode indicates adjusted dive times that are available for the next dive, based on residual nitrogen or oxygen accumulation (whichever is in control) following the last dive and surface interval.

△ NOTE: No Decompression Dive Times in Plan Mode are based on the FO2 setting for Gas 1. The FO2 setting for Gas 2 is not utilized for Plan calculations.

Plan Mode can only be accessed while viewing NORM SURF MAIN.

- Pressing and releasing the S button momentarily (< 2 sec) while viewing the NORM Surface Main screen is displayed will access the NORM Plan Lead-in screen.

Plan Lead-in, information includes (Fig. 40):

- > Graphic FO2 with wave/clock/profile icons.
- > PO2 Alarm Set Point and graphic PO2, if FO2 is set for Nitrox, blank if set for Air.
- > Tank 1 icon indicating that FO2 is for Gas (mix) 1.
- > FO2 Set Point for Gas 1, Air or 21 to 50.



Fig. 40 - PLAN LEAD - IN
(set for Nitrox)

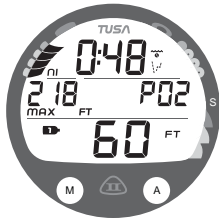

Fig. 41A - PLAN
(Nitrogen control)

- After dives, press and release the A button momentarily (< 2 sec) to access the Time to Fly screen, then again to access the Desat screen.
- Press and release the S button momentarily and repeatedly (< 2 sec each time) to access the first Plan Depth/Time screen and step upward through the sequence of screens.

The screens will sequence through Depths from 30 up to 190 FT (9 to 57 M), or the Max Depth that will allow theoretical No Deco Dive Time of at least 1 minute based upon the previous dive profiles in a series of repetitive dives and taking into account descent and ascent rates of 60 FPM (18 MPM).

△ NOTE: When the Conservative Factor is set ON, No Deco Dive times are reduced to the values of the next 3,000 foot (915 meter) higher Altitude.



Fig. 41B - PLAN
(O2 control)

- Plan Depth/Time**, information includes (Fig. 41A/B:
- > NiBG or O2BG (4 segments) indicating which (Nitrogen or O2) is in control of calculations based on previous dives.
 - > Dive Time (hr:min) allowed for the Depth displayed, with wave/clock/profile icon.
 - > Max Depth allowed for the PO2 Alarm value set with MAX and FT (or M) icons and graphic PO2.
 - > Tank 1 icon indicating Gas (mix) 1.
 - > Plan Depth with FT (or M) icon.

- Press and release the S button momentarily and repeatedly (< 2 sec each time) to increase the Planned Depth in increments of 10 FT (3 M), displaying the information one screen at a time.
- Depressing the M button for 2 seconds, or if no button is pressed for a period of 2 minutes, operation will revert to the NORM Surface Main screen.

FLY MODE

Time to Fly is a counter that begins counting down 10 minutes after surfacing from a dive from 23:50 to 0:00 (hr:min).

- Pressing and releasing the A button momentarily 2 times (< 2 sec each time) while viewing the NORM Surface Main screen, or 1 time while viewing the GAUG Surface Main screen, will access Fly Mode.

NORM SURF MAIN >> PLAN >> FLY
 GAUG SURF MAIN >> FLY

Time to Fly, information includes (Fig. 42):

- > Graphic FLY.
- > Countdown Time (hr:min) with clock icon.
- If in NORM, pressing and releasing the A button momentarily (< 2 sec) will access the Desat Time screen.
- If in GAUG, pressing and releasing the A button will revert to the GAUG Surface Main screen.

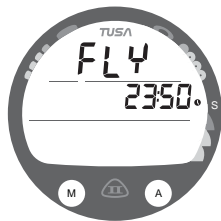

Fig. 42 - TIME TO FLY

- Depressing the M button for 2 seconds, or if no button is pressed during a 2 minute period, operation will revert to the NORM (or GAUG) Surface Main screen.
- Pressing the L button will activate the Backlight.

DESAT MODE (NORM only)

The Time to Desaturate counter provides calculated time for Tissue Desaturation at sea level taking into consideration the Conservation Factor setting. It begins counting down 10 minutes after surfacing from a dive, counting down from 23:50 max to 0:00 (hr:min).

When the Countdown reaches 0:00, which will generally occur prior to the Fly countdown reaching 0:00, the Dsat screen remains in the sequence of accessible NORM screens displaying 0:00 until the Fly counter turns the unit Off 24 hours after a last dive.

- > The SAT screen is not displayed after a Violation Dive.
- > Desaturation requiring Times greater than 24 hours will display 23: - - .
- > In the event that Time to Desaturate still remains at the end of 24 hours, the added time will be zeroed.



Fig. 43 - DESAT TIME

Desat Time, information includes (Fig. 43):

- > Graphic SAT.
- > Countdown Time (hr:min) with clock icon.
- Pressing and releasing the A button momentarily (< 2 sec) will revert to the NORM Surface Main screen.

- Depressing the M button for 2 seconds, or if no button is pressed during a 2 minute period, operation will revert to the NORM Surface Main screen.
- Pressing the L button will activate the Backlight.

NORM/GAUG LOG MODE

Log Mode displays information from the latest 24 NORM and/or GAUG dives sequentially in reverse order (the most recent first). Log information is retained until over written by another dive. Battery removal will not affect the Log data stored for viewing.

- > After exceeding 24 dives, data from the most recent dive completed will be recorded in the Log and the oldest dive's data deleted.
- > Dives will be numbered 1 to 24 starting at #1 each time a new series of dives begins. After it shuts Off 24 hours after a dive, the first dive of the next new series will be #1.
- Log Mode can be accessed by pressing and releasing the A button momentarily (< 2 sec) while viewing the NORM or GAUG Surface Main screen.
- > The most recent dive's Log Preview screen will be displayed.
- Pressing and releasing the A button momentarily (< 2 sec) while viewing the Preview screen of the most recent dive will bypass Log Mode and access the History Mode.
- Depressing the S button will then scroll back through the previous dives' Preview screens at a rate of 8 per second until released.
- > Log screens remain on display until further button action occurs.
- Depressing the M button for 2 seconds, or if no button is pressed during a 2 minute period, operation will revert to the NORM (or GAUG) Surface Main screen.
- Pressing the L button will activate the Backlight.



Fig. 44 - LOG PREVIEW

Log Preview, information includes (Fig. 44):

- > Log (book) icon.
- > Graphic NOR (or GAU).
- > Dive Mode (wave/clock/profile) icon, if NORM.
- > Date (month.day or day.month) the dive was conducted.
- > Time of Day the dive began (hr:min) with clock icon and AM (or PM) icon if set for 12 Hour Format.
- > # icon and dive number (1 to 24) for that series.

- Pressing and releasing the S button momentarily (< 2 sec) will access that dive's Log Data 1 screen.

Log Data 1, information includes (Fig. 45):

- > NiBG with the max segment flashing, others fixed up to end of dive accumulation. All flashing if Violation.
- > Log (book) icon.
- > Pre dive Surface Interval time (hr:min) with clock/wave icon, 10 - through 23 - for times greater than 9 hours and 59 minutes, (- : -) if no previous dive that period.
- > Temperature (minimum recorded that dive) with degrees icon and graphic F (or C).
- > Elapsed Dive Time (hr:min) with wave/clock icon.
- > Max Depth with MAX and FT (or M) icons.
- > ASC representing max Ascent Rate recorded for 4 seconds.

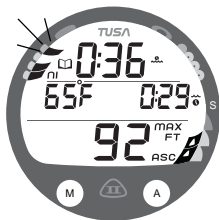

Fig. 45 - LOG DATA 1

- Pressing and releasing the S button momentarily (< 2 sec) will access Log Data 2.
- Pressing and releasing the A button momentarily (< 2 sec) will revert to the NORM (or GAUG) Surface Main screen.
- Depressing the M button for 2 seconds, or if no button is pressed during a 2 minute period, operation will revert to the NORM (or GAUG) Surface Main screen.
- Pressing the L button will activate the Backlight.

Log Data 2 (only if Nitrox), information includes (Fig. 46):

- > Log (book) icon.
- > Graphic FO2 (at top) with FO2 Set for Gas 1 for that dive (at bottom).
- > O2BG segments representing O2 accumulated at the end of the dive.
- > Max PO2 achieved (ATA) with MAX icon and graphic PO2.
- > Tank 1 icon representing Gas (mix) 1.

- Pressing and releasing the S button momentarily (< 2 sec) will access the previous dive's Log Preview screen.
- Pressing and releasing the A button momentarily (< 2 sec) will revert to the NORM (or GAUG) Surface Main screen.
- Depressing the M button for 2 seconds, or if no button is pressed during a 2 minute period, operation will revert to the NORM (or GAUG) Surface Main screen.
- Pressing the L button will activate the Backlight.

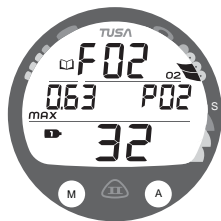

Fig. 46 - LOG DATA 2



Fig. 47 - HISTORY 1

HISTORY MODE

History Mode displays information for NORM and/or GAUG Dives. Information is retained indefinitely. Battery removal will not affect the History data stored for viewing.

- History Mode can be accessed by pressing and releasing the A button momentarily 2 times (< 2 sec each time) while viewing the NORM or GAUG Surface Main.

History 1, information includes (Fig. 59):

- > Graphic HIS.
- > Total Elapsed Dive Time recorded, up to 9999, with graphic Hour and clock icon.
- > Total number of all dives recorded, up to 999, with # icon.
- Pressing and releasing the S button momentarily (< 2 seconds) button will access the History 2 screen.

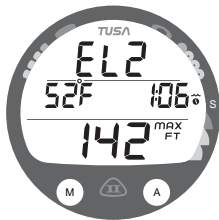

Fig. 48 - HISTORY 2

History 2, information includes (Fig. 60):

- > Altitude graphic SEA (or EL 2 through EL 7), max level.
- > Temperature, lowest recorded with icon and F (or C).
- > Max EDT (hr:min) for a single dive with wave/clock icon.
- > Max Depth ever recorded with MAX and FT (or M) icons.
- Pressing and releasing the A button momentarily (< 2 sec) will revert to the NORM (or GAUG) Surface Main screen.

- Depressing the M button for 2 seconds, or if no button is pressed during a 2 minute period, operation will revert to the NORM (or GAUG) Surface Main screen.
- Depressing the S button for 2 seconds will activate the Backlight.

 **NOTE: FREE Dives are not recorded in the viewable Log or History. The data is stored in memory for subsequent download to the TUSA PC Interface program.**

FREE Mode uses the NORM/GAUG settings for -

- >> **Time/Date**
- >> **Wet Activation**
- >> **Units**
- >> **Conservative Factor**
- >> **Backlight Duration**



WARNINGS:

Making decompression dives without the proper preparation and training will place you in an unnecessarily dangerous situation.

Existing data for making planned decompression dives is limited, and virtually non-existent for repetitive decompression diving.

Decompression diving greatly increases your risk of decompression sickness.

Special training, equipment, and support are necessary for diving deeper than the maximum recommended sport diving depth limit(s).

NORM DIVE MODES

NO DECO DIVE TIME REMAINING (NDC)

The Element II constantly monitors No Decompression status.

NDC is the maximum amount of time that you can stay at your present Depth before entering a Decompression situation. It is calculated based on the amount of Nitrogen absorbed by hypothetical tissue compartments.

The rates each of these compartments absorb and release Nitrogen is mathematically modeled and compared against a maximum allowable Nitrogen level.

Whichever one is closest to this maximum level is the controlling compartment for that Depth. Its resulting value will be displayed as NDC (Fig. 49a) and the NiBG (Fig. 49b).

As you ascend from Depth during a dive, the NiBG segments will recede as control shifts to slower compartments.

This is a feature of the Decompression model that is the basis for multilevel diving, one of the most important advantages that the Element II dive computer offers.

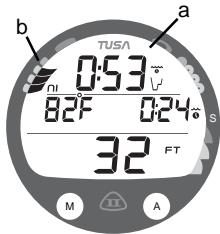

Fig. 49 - NDC (DTR)

OXYGEN ACCUMULATION

If FO₂ was set for a numerical value (Nitrox), the O₂BG (Fig. 50a) will add segments to represent oxygen accumulation for that dive, or 24 hour period, whichever amount is greater.

If O₂ reaches 100% of the allowed limit (300 OTU), the graphic O₂ will replace NDC. High O₂ is described later.

ASCENT RATE INDICATOR (ASC)

The ASC shows how fast you are ascending. When you exceed the maximum recommended Ascent Rate for the depth you are at (see chart on page 17), all segments of the ASC will flash (Fig. 51) and the graphic SLO will flash (Fig. 51a), replacing NDC time (or GAU graphic). The flashing will stop and NDC time (or GAU graphic) restored when the audible is silenced or your Ascent Rate is slowed below the alarm value.

The Ascent Rate alarm is based upon 2 sets of speeds which change at a reference depth of 60 FT (18 M).



WARNING: At depths greater than 60 FT (18 M), Ascent Rates should not exceed 60 FPM (18 MPM). At depths of 60 FT (18 M) and shallower, Rates should not exceed 30 FPM (9 MPM).

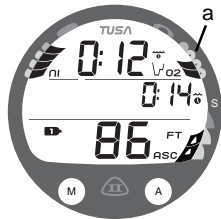

Fig. 50 - O₂BG

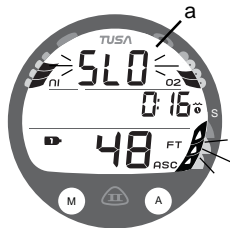

Fig. 51 - ASC

NORM NO DECOMPRESSION DIVE MODE

When the Wet Activation feature is set ON, the Element II will enter the NORM No Decompression Dive Mode any time you descend to 5 FT (1.5 M) for 5 seconds, even if not yet activated.

When the Wet Activation feature is set OFF, the Element II will not enter Dive Mode upon descent unless it is activated first.

NORM No Deco Main, information includes (Fig. 52) -

- > NiBG, O2BG, ASC - if applicable
- > DTR (hr:min) with NDC (wave/clock/profile) icon
- > EDT (hr:min) with Elapsed Dive Time (wave/clock) icon
- > Tank icon representing the Gas selected (1 or 2)
- > Current Depth with FT (or M) icon

- Press/release the A button (< 2 sec) to view ALT 1.
- Depress the A button for 2 seconds to access the Deep Stop Preview screen, if activated.
- Press/release the S button (< 2 sec) to acknowledge alarms.
- Depress the M button for 2 seconds to access the Gas Switch Routine.
- Depress the S button for 2 seconds to activate the Backlight.

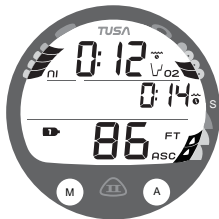

Fig. 52 - NO DECO MAIN

NORM No Deco ALT 1, information includes (Fig. 53) -

- > Temperature with degrees icon and graphic F (or C)
 - > Time of Day (hr:min) with AM (or PM) and clock icons
 - > Max Depth with MAX and FT (or M) icons
- Press/release the A button to access ALT 2.
 - Operation will revert to the Main after 5 seconds if A is not pressed.

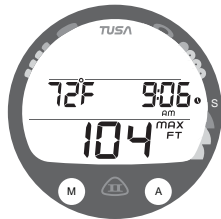

Fig. 53 - NO DECO ALT 1

NORM No Deco ALT 2, information includes (Fig. 54) -

- > Graphic FO2
 - > PO2 (ATA) with graphic PO2
 - > Tank icon representing the Gas selected (1 or 2)
 - > FO2 set for the Gas selected (1 or 2)
- Operation will revert to the Main Display after 5 seconds or if the A button is pressed/released.

NOTE: ALT screens cannot be accessed during the time when an Alarm is sounding.

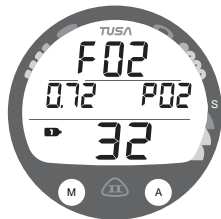

Fig. 54 - NO DECO ALT 2



Fig. 55 - DS PREVIEW

No Deco Deep Stop

On any No Deco dive in which Depth exceeds 80 FT (24 M), a Deep Stop Preview screen (Fig. 55) can be accessed that will display the graphic DS (meaning Deep Stop) and a recommended Stop Depth calculated to be 1/2 the Max Depth and a Stop Time of 02:00 (2 minutes) with DS and STOP icons. It will revert to the Main after 5 seconds.

- The intent of this screen is to suggest that a Stop should be made as indicated to help reduce tissue nitrogen loading prior to final ascent.
- The Preview screen will not be available for viewing once you ascend above the Stop Depth.

△ NOTE: The Deep Stop is not required and although recommended, it does not have to be taken. There is no penalty if the Stop is ignored and ascent (or other activity) is continued.

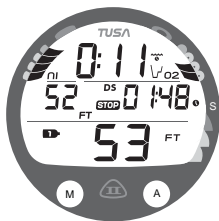

Fig. 56 - DS MAIN

Upon ascending to within 10 FT (3 M) below the calculated Stop Depth, the DS Main screen (Fig. 56) will appear displaying the calculated Stop Depth with FT (or M), DS, and STOP icons and the Timer that counts down from 02:00 to 0:00 (min:sec) with clock icon. Also displayed will be NDC (hr:min) with wave/clock/profile mode icon, Tank icon (Gas 1 or 2), current Depth with FT (or M) icon, and applicable bar graphs.

Press and release the A button (< 2 seconds) to access the ALT 1 screen (Fig. 57A) that displays Elapsed Dive Time, press it again to view the ALT 2 screen (Fig. 57B) that displays Temperature, Time, and Max Depth, then if a Nitrox dive press it again to view ALT 3 that displays FO2 and PO2 (Fig. 57C).

When the countdown reaches 0:00, the No Deco Main will be displayed and the Deep Stop feature will be disabled for the remainder of that dive.

In the event that you descend 10 FT (3 M) below, or ascend 10 FT (3 M) above the Stop Depth, for more than 10 seconds during the countdown, the No Deco Main will be displayed and the Deep Stop feature will be disabled for the remainder of that dive.

If you return to within the +/- 10 FT (3 M) range during the 10 seconds, the Deep Stop Main will reappear with the countdown still in progress.

The Deep Stop feature will be disabled, and its screens not displayed, for the remainder of that dive, if you enter Deco or High O2 (80%), or descend deeper than 190 FT (63 M).

During High PO2 (=> Alarm Set Point), the DS screen information will be replaced with High PO2 information.



Fig. 57A - DS ALT 1

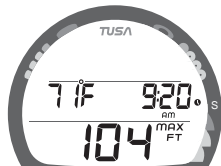

Fig. 57B - DS ALT 2



Fig. 57C - DS ALT 3

No Deco Safety Stop (Fig. 58)

Upon ascending to 20 FT (6 M) on any No Deco dive in which Depth exceeded 30 FT (9 M), a Safety Stop screen will appear displaying a recommended Stop at 15 FT (4.5 M) with a Countdown Timer that counts down from 03:00 to 0:00 (min:sec).

The Safety Stop will be displayed until the countdown times out, or you descend below 30 FT (9 M) during the countdown, or you surface during the countdown.

- Like the Deep Stop, there is no Penalty for surfacing prior to completing the Safety Stop.
- There is no Preview screen associated with the Safety Stop.

Safety Stop Main display information includes NDC (hr:min) with wave/clock/profile mode icon, Stop Depth (15 FT or 4.5 M), STOP icon, Countdown Timer (min:sec) with clock icon, Tank icon (Gas 1 or 2), Current Depth with FT (or M) icon, and applicable bar graphs.

- Press and release the A button to access the ALT displays which are similar to those previously described for the Deep Stop (page 59).



Fig. 58 - SAFETY STOP
MAIN

CAUTIONARY MODES

DECOMPRESSION

Decompression mode activates when theoretical No Decompression time and depth limits (NDLs) are exceeded.

Upon Entry into Decompression, the Audible Alarm will sound until acknowledged or for 10 seconds. While the audible is sounding, the UP Arrow icon, Stop Bar icon, and full NiBG will flash to alert you.

Deco Entry, information includes (Fig. 59)

- > Full NiBG, flashing until the audible is silenced, O2BG and ASC if applicable
- > TAT** (hr:min) with Deco mode icon (wave/clock/profile/stop bar), stop bar flashing until the audible is silenced
- > Stop Depth required with FT (or M) and STOP icons
- > Stop Time (hr:min) required clock icon
- > Tank icon representing the Gas selected (1 or 2)
- > Current Depth with FT (or M) icon

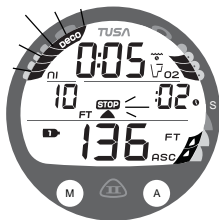

- > The UP Arrow icon will flash until you ascend to within 10 FT (3 M) below the Stop Depth indicated, then it will be blank.
- Press/release the S button to acknowledge/silence the Audible Alarm.
- Depress the S button for 2 seconds to activate the Backlight.

**TAT represents Total Ascent Time which includes time required for all deco stops plus vertical ascent time to the surface.

Fig. 59 - DECO ENTRY

△ NOTE: Upon entry into Deco, the Deep Stop and Safety Stop features are disabled for the remainder of that dive, even when the Deco obligation is complete and No Deco status is regained.

Managing Decompression Stops

To fulfill your decompression obligation, you should make a safe controlled Ascent to a depth slightly deeper than, or equal to, the Stop Depth indicated and decompress for the Time indicated.

The amount of decompression credit time that you receive is dependent on Depth, with slightly less credit given the deeper you are below the Stop Depth indicated.

Deco Stop Main, information includes (Fig. 60) -

- > Full NiBG (solid), O2BG if applicable
 - > TAT (hr:min) with Deco mode icon (Stop bar solid)
 - > Stop Depth with FT (or M), Arrow, and STOP icons
 - > Stop Time (hr:min) with clock icon
 - > Tank icon (Gas 1 or 2)
 - > Current Depth with FT (or M) icon
-
- Press and release the A button (< 2 sec) to view ALT screens which are similar to those previously described for the Deep Stop.
 - Depress the M button for 2 seconds to access the Gas Switch Routine.
 - Depress the S button for 2 seconds to activate the Backlight.



Fig. 60 - DECO STOP MAIN

CONDITIONAL VIOLATION (CV)

If you ascend shallower than the calculated Deco Stop Depth, the Audible Alarm will sound, and no off gassing credit will be given, until you descend below the Stop Depth.

If you descend below the required Ceiling before 5 minutes have elapsed, operation will continue to function in Deco and off gassing credit will resume.

CV Main, information includes (Fig. 61) -

- > Full NiBG (solid), O2BG if applicable
- > TAT (hr:min) with Deco mode icon (stop bar flashing)
- > Stop Depth with FT (or M) icon, and STOP icon (flashing)
- > Stop Time (hr:min) with clock icon
- > Down Arrow icon (flashing)
- > Tank icon (Gas 1 or 2)
- > Current Depth with FT (or M) icon

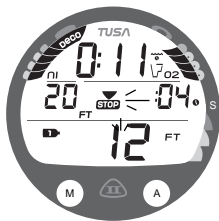

Fig. 61 - CV MAIN

- Press and release the A button (< 2 sec) to view ALT screens which are similar to those previously described for the Deep Stop.
- Depress the M button for 2 seconds to access the Gas Switch Routine.
- Depress the S button for 2 seconds to activate the Backlight.

△ NOTE: Upon entry into the following Violation modes, the Alarm will sound, even if Set OFF. When these events occur, the Alarm cannot be acknowledged (silenced) by pressing the S button.

DELAYED VIOLATION #1 (DV1)

If you remain above the required Deco Ceiling Depth for more than 5 minutes, the full NiBG will flash until you descend below the required Stop Depth.

This is a continuation of a Conditional Violation.

DV1 Main, information includes (Fig. 62) -

- > Full NiBG (flashing), O2BG if applicable
 - > TAT (hr:min) with Deco mode icon (stop bar flashing)
 - > Stop Depth with FT (or M) icon and STOP icon (flashing)
 - > Stop Time (hr:min) with clock icon
 - > Down Arrow icon (flashing)
 - > Tank icon (Gas 1 or 2)
 - > Current Depth with FT (or M) icon
-
- Press and release the A button (< 2 sec) to view ALT screens which are similar to those previously described for the Deep Stop.
 - Depress the M button for 2 seconds to access the Gas Switch Routine.
 - Depress the S button for 2 seconds to activate the Backlight.

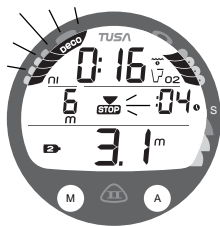

Fig. 62 - DV1 MAIN

DELAYED VIOLATION #2 (DV2)

If the Decompression obligation requires a Ceiling Depth between 60 FT (18 M) and 70 FT (21 M), the full NiBG and TAT (Total Ascent Time) digits will flash.

When this occurs, you must make a controlled ascent to just deeper than, and stay as close as possible to, 60 FT (18 M) without causing the NiBG and TAT to flash. When the Deco Stop Depth indicates 50 FT (15 M), etc., you can ascend to those Stop Depths and continue decompressing.

DV2 Main, information includes (Fig. 63) -

- > Full NiBG (flashing), O2BG if applicable
 - > TAT (hr:min) flashing with Deco mode icon
 - > Stop Depth with FT (or M) icon and STOP icon
 - > Stop Time (hr:min) with clock icon
 - > Tank icon (Gas 1 or 2)
 - > Current Depth with FT (or M) icon
-
- Press and release the A button (< 2 sec) to view ALT screens which are similar to those previously described for the Deep Stop (page 73).
 - Depress the M button for 2 seconds to access the Gas Switch Routine.
 - Depress the S button for 2 seconds to activate the Backlight.

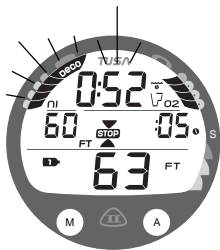

Fig. 63 - DV2 MAIN

DELAYED VIOLATION #3 (DV3)

If you descend deeper than the MOD (Max Operating Depth) of 330 FT (99.9 M), the Up Arrow icon will flash, and the Current Depth will only display 3 dashes (- - -) flashing signifying that you are Out of Range. Max Depth on the ALT screen will only indicate 3 dashes (- - -).

Upon ascending above 330 FT (99.9 M), the Current Depth display will be restored, however, Max Depth will only display 3 dashes for the remainder of that dive. Also, the log for that dive will display 3 dashes as the Max Depth achieved.

DV3 Main, information includes (Fig. 64) -

- > NiBG, O2BG, ASC - if applicable
 - > DTR as 0:00 (hr:min) with wave/clock/profile icon
 - > EDT (hr:min) with wave/clock icon
 - > Tank icon representing the Gas selected (1 or 2)
 - > Up Arrow icon (flashing)
 - > Current Depth as 3 dashes (- - -) (flashing) with FT (or M) icon
- Press/release the A button (< 2 sec) to view ALT displays which are similar to those previously described for the No Deco.
 - Press/release the S button (< 2 sec) to acknowledge alarms.
 - Depress the S button for 2 seconds to activate the Backlight.

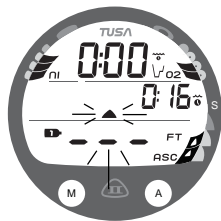

Fig. 64 - DV3 MAIN

VIOLATION GAUGE MODE (VGM)

If calculations require a Deco Stop Depth greater than 70 FT (21 M), or if Deco is entered while operating in FREE Mode (described later), operation will enter Violation Gauge Mode (VGM) for the remainder of that dive and for 24 hours after surfacing. VGM turns the Element II into a digital instrument without any nitrogen or oxygen calculations or monitoring functions or displayed information until 24 contiguous hours elapse on the surface with no dives.

VGM Main, information includes (Fig. 65) -

- > Full NiBG and full O2BG, all segments flashing
- > Graphic VIO, flashing until the audible is silenced then solid
- > EDT (hr:min) with wave/clock icon
- > Tank icon representing the GAS selected (1 or 2)
- > Current Depth with FT (or M) icon
- > Up Arrow icon, flashing until on surface

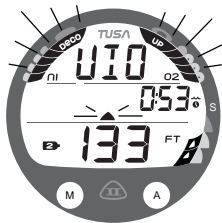

Fig. 65 - VGM MAIN

The Element II will also enter VGM 5 minutes surfacing from a dive in which a Delayed Violation (1, 2, or 3) occurred.

Once on the surface, VGM does not allow access to the Set F, Plan, Fly, and Dsat features/screens.

The countdown timer that appears when you try to access Fly is only provided to inform you of the time remaining before normal operation can resume with full features and functions.

In the event that a dive is made during the 24 hour period, a full 24 hour surface interval must then be served before all functions are restored.

VGM Main (on surface), information includes (Fig. 66) -

- > Full NiBG and full O2BG, all segments flashing
 - > Surface Interval Time (hr:min) with wave/clock icon
 - > Graphics Vio and Nor alternating, each on 2 seconds
 - > Tank 1 icon representing Gas 1
 - > Dive number with # icon
 - > Battery icon if low battery condition
-
- Depressing the A button for 2 seconds will access the NORM SURF ALT screen for 5 seconds.
 - Pressing and releasing the A button (< 2 sec) will access Log Mode, then pressing it again will access History Mode.
 - Depress the S button for 2 seconds to activate the Backlight.
 - Depressing both the A and S buttons simultaneously for 2 seconds will access the Set Menu.
 - Depressing the M for 2 seconds will access the GAUG Surface Main screen, then another 2 second press will access the FREE Surface Main screen.



Fig. 66 - VGM MAIN
(on surface)

HIGH PO2

When partial pressure of oxygen (PO2) becomes equal to, or greater than, 0.2 (ATA) less than the PO2 Alarm value set; the Audible will sound. Note that while in Deco, High PO2 will only alarm at 1.60.

- Press/release the S button to acknowledge the alarm.
- > The graphic PO2 and Up Arrow icon will be displayed flashing on the Main screen (Fig. 67) until the audible is silenced, then the graphic PO2 will alternate with NDC time until PO2 decreases to 0.2 below the alarm Set Point.
- > The value of PO2 can be viewed on the ALT 2 screen.
- Press/release the A button to view the ALT screens.
- Depress the M button for 2 seconds to access the Gas Switch routine.
- Depress the S button for 2 seconds to activate the Backlight.



Fig. 67 - HIGH PO2 MAIN
(during audible)

- > If PO2 continues to increase, the value (displayed on the ALT screen) will increase in increments of .01 (ATA).
- > When PO2 reaches the Alarm Set Point, the Audible Alarm will sound again.
- > The Up Arrow icon will flash on the Main screen until PO2 decreases to 0.2 (ATA) below the alarm Set Point.
- > If High PO2 ($= > 1.60$) occurs while in Deco, the graphic PO2 will be displayed in place of TAT until PO2 decrease below 1.60. The Up Arrow will not indicate ascent.

HIGH O2

The O2BG (Fig. 68a) represents oxygen accumulated as a result of the repetitive Nitrox dives you have conducted during that operating period. The O2BG lets you monitor how close you are coming to the limits of oxygen exposure.

If the theoretical amount of oxygen accumulated reaches the limit for a single exposure, or 24 hour period (300 OTU = 100%), the graphic O2 replaces NDC time and the full O2BG and Up Arrow icon will be displayed flashing (Fig. 69).

The Audible Alarm will sound. When the audible is silenced, the O2 graphic becomes solid until O2 decreases below 100%.

- Press/release the S button to acknowledge the alarm.
- Press/release the A button to view the ALT screens.
- Depress the M button for 2 seconds to access the Gas Switch routine.
- Depress the S button for 2 seconds to activate the Backlight.

Upon surfacing, operation will lock in to NORM mode until the O2BG recedes to 4 segments. Access to GAUG and FREE modes will be blocked.

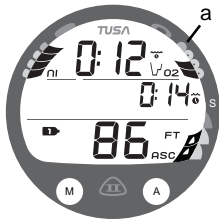

Fig. 68 - NITROX DIVE

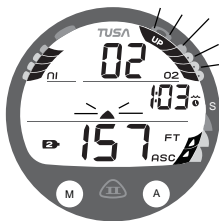

Fig. 69 - HIGH O2



WARNINGS AND SAFETY RECOMMENDATIONS

- The percentage of oxygen (FO₂) in the Nitrox mix being used must be 'set before each nitrox dive', unless the FO₂ 50% Default feature is set OFF (a user setting).
- Plan Mode provides predicted times for subsequent dives. Depending on cylinder size, breathing gas consumption, and oxygen accumulation, you may have less time available than indicated because of breathing gas quantity or other limitations.
- Until it has shut itself off, you must not use the Element II at a different Altitude than the Altitude at which it was activated. Doing so will result in an error equal to the difference in barometric pressure, and possibly a false dive mode with erroneous data.
- To provide proper Altitude compensation, the Element II must be manually activated at the new altitude. Dive computers, such as the Element II cannot sense changes in barometric pressure if activated by immersion in water at higher Altitudes.
- Use the Caution Zone of the Nitrogen Bar Graph as a visual reference to provide a greater margin of protection between you and the No Decompression Limits.
- Every effort should be made to keep each of the Bar Graphs in the normal zone throughout your dives to reduce your risk of exposure to decompression sickness, oxygen toxicity, and the effects of excessive ascent rates.

SWITCHING GAS MIXES

SWITCHING GAS MIXES (NORM only)

During NORM Dives, the FO2 calculations/displays can be switched from Gas 1 to 2.

- > Switching Gas cannot be performed while on the surface.
- > Every dive begins with Gas 1 and 10 minutes after surfacing from a multiple gas dive, operation defaults to the Gas 1 FO2.
- > Access to Gas Switching screens can only be accomplished during the time that a NORM Dive Main screen is being displayed and cannot be performed during the time that an Alarm is sounding.

△ NOTE: If a Switch to a new Gas mix would expose the diver to a prohibitive PO2 level of 1.60 ATA or greater, the Audible Alarm will sound and the graphics DO - NOT - CHNG GAS will flash on the display (Fig. 70) until the Audible is silenced.



Fig. 70 - DO NOT CHANGE
GAS ALARM

Due to the possibility that sufficient air may not be available in the Switch From tank to complete the dive, the Switch to the prohibitive Mix is still allowed.

- > If the Switch is made to the prohibitive Mix, the High PO2 Alarm will activate.
- > If in Deco, the graphic PO2 will flash in place of TAT until PO2 decreases below 1.60, then TAT will be restored.

Switching of Gas Mixes can only be performed during the time that a Gas Switch Preview screen is being displayed.

To access the Preview screens while viewing a NORM Dive Main screen.

- Depress the M button for 2 seconds to view the Gas 1 Preview screen.
 - Press and release the M button momentarily (< 2 sec) while the Gas 1 Preview screens is displayed to view the Gas 2 Preview screen.
 - Depress the M button for 2 seconds while viewing a Preview screen to Switch FO2 to that Gas.
- > Operation will revert to the NORM Main screen after 10 seconds of no further M button action.

Gas 1 Switch Preview, information includes (Fig. 71) -

- > Graphics FO2 and - 1
- > Tank icon representing Gas 1
- > Graphic Air or FO2 value set

Gas 2 Switch Preview, information includes (Fig. 72) -

- > Graphics FO2 and - 2
- > Tank icon representing Gas 2
- > Graphic Air or FO2 value set

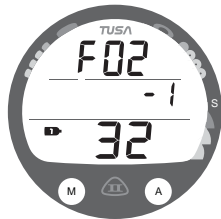

Fig. 71 - GAS 1 PREVIEW

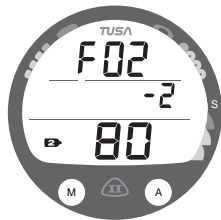
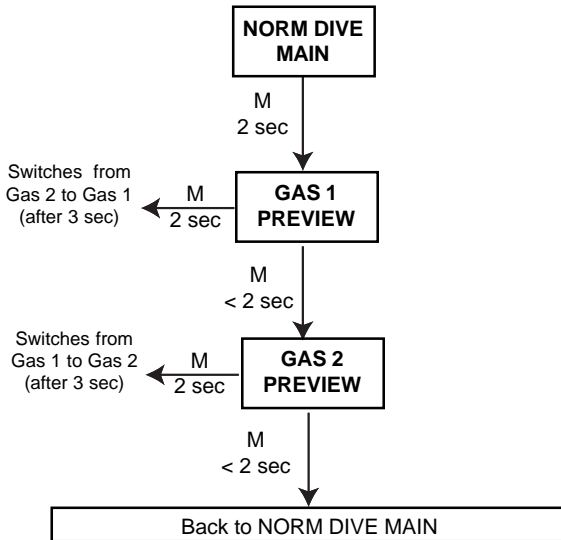

Fig. 72 - GAS 2 PREVIEW

GAS SWITCH ROUTINE



NORM POST DIVE MODES

POST DIVE FIRST 10 MINUTES ON SURFACE

When you ascend to 2 FT (0.6 M) for 1 second, the Surface Main screen will be displayed. If you descend during the first 10 minutes after surfacing (referred to as the Transition Period), time underwater will be considered a continuation of that dive. The time at the surface (if less than 10 minutes) will not be added as Dive Time.

NORM Surface Main, information includes (Fig. 73) -

- > NiBG, and O2BG (if Nitrox)
- > Surface Interval Time (hr:min) with colon flashing during the first 10 minutes and clock/wave icon
- > Graphic Nor
- > Tank icon representing Gas in use, #1 after 10 min (default on surface)
- > Number of that dive with # icon
- > Battery icon if a Low Battery condition exists, flashing if Too Low



Fig. 73 - NORM SURF MAIN
(during first 10 min)

During the Transition Period, ALT displays and the Log and History can be accessed. Other modes (e.g., Plan, Fly, Sat, Set) are accessible after 10 minutes on the surface.

- Press and release the A button (< 2 sec) to access the Log Preview screen for that dive.
- Depress the A button for 2 seconds to access SURF ALT.
- Press the S button for 2 seconds to activate the Backlight.

POST DIVE AFTER 10 MINUTES ON SURFACE

Once 10 minutes have elapsed, the Surface Interval time colon will stop flashing indicating that the Dive and Transition Period are completed, and a subsequent descent will be considered a new dive.

You will then have full access to all NORM DC surface modes (e.g., Plan, Fly, Sat, Log, Hist, Set, etc.).

- Press and release the S button momentarily (< 2 sec) to access Plan Mode.
 - > Adjusted No Deco Limits will be displayed based on residual nitrogen and accumulated oxygen calculated to be remaining from the previous dives.
- While viewing the first Plan screen, press and release the A button momentarily (< 2 sec) to access the Time to Fly screen (Fig. 74), then press it again to access Dsat Time screen (Fig. 75).
 - > The Desat counter provides calculated time for tissue desaturation at sea level.
 - > If a Violation occurred during the dive, the Desat screen will not be displayed.

Once 2 hours have elapsed after surfacing from a dive, only the Fly and Sat screens will be displayed (alternating), counting down to 0:00 (hr:min), then the unit will shut off.

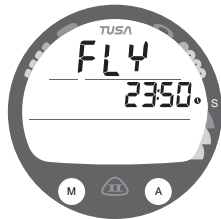

Fig. 74 - TIME TO FLY

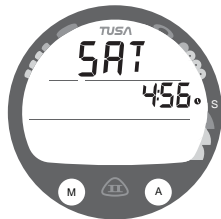

Fig. 75 - DSAT TIME

UPLOADING SETTINGS AND DOWNLOADING DATA

The Element II is configured with a Data Port located on the back of the left side that enables it to be connected to a PC through a USB port using a special Interface Cable that is available as an optional accessory.

The USB Driver required for the Interface system is downloadable from tusa.com.

The Settings Upload portion of the program provided can be used to set/change the Set A group (Alarms), Set U group (Utilities), and Set T group (Time/Date) using the same Interface System. The Set F group (FO2) and FREE Mode Alarms must be entered using the Element II's button controls.

Information available for retrieval (Download) from the Element II to the PC Download portion of the program includes dive number, surface interval time, maximum depth, elapsed dive time, start date, start time, lowest temperature underwater, sampling rate, dive profile, Set Points, NiBG, O2BG, and Gas Switching events.

The Element II checks for the presence of an interface device connection to the Data Port once every second while in Surface mode. Checks are not made if the Wet Activation contacts are wet. Upon sensing an interface connection, the requesting device (PC) connects to the Element II and is prepared for Upload of settings or Download of data which are then initiated using the PC program.

Prior to attempting to Download data from your Element II or Upload Settings to it, review the HELP section of the interface program. Recommended is to print those sections of HELP that you consider appropriate for your Interface activities.

GAUGE OPERATING MODE

DIGITAL GAUGE MODE (GAUG)

When GAUG is selected as the operating mode, the Element II will operate as a Digital Depth Gauge/Timer without performing nitrogen and oxygen calculations.

- To access GAUG mode while the NORM Surface Main screen is displayed, press the M button 1 time for 2 seconds.
- If the graphic GAU is flashing, Gauge Mode can be selected as the operating dive mode by pressing and releasing the M button momentarily (< 2 sec). The graphic GAU becomes solid and Gauge Mode is selected.
- If no Gauge dive has been conducted, pressing the M button for 2 seconds will advance to the Free Surface Main screen.

NORM SURF >> GAUG SURF >> FREE SURF

Gauge Surface Main, information includes (Fig. 76) -

- > Surface Interval Time (hr:min) with clock/wave icon
- > Graphic GAU, flashing if not previously selected
- > Number of the recent dive conducted, 0 if no dive yet that period, with # icon
- > Battery icon if a Low Battery condition, flashing if Too Low

Upon descending to 5 FT (1.5 M) for 5 seconds, the Element II will enter Gauge Dive Mode.

- Press and release the A button momentarily (< 2 sec) to access Log, then again to access History.



Fig. 76 - GAUG SURF MAIN

- Depress the A button for 2 seconds to the GAUG SURF ALT screen (Fig. 77 - Altitude, Temperature, Time of Day).
- Depress the A and S buttons simultaneously for 2 seconds to access the Set menu (F >> A >> U).
- Press and release the S button momentarily (< 2 sec) to access the Time to Fly screen, if a dive was conducted.
- Depress the S button for 2 seconds to activate the Backlight.

△ NOTE: Once a dive is made in Digital Gauge Mode, you must wait 24 contiguous hours after surfacing before the Element II resets and will operate as an Air or Nitrox dive computer in NORM Mode or FREE Dive Mode.

Gauge Dive Main, information includes (Fig. 78) -

- > Graphic GAU
- > Elapsed Dive Time (hr:min) with wave/clock icons
- > Depth with FT (or M) icon
- > ASC when ascending
- Press and release the A button momentarily (< 2 sec) to access the ALT screen.
- Press and release the S button momentarily (< 2 sec) to acknowledge/silence Alarms.
- Depress the S button for 2 seconds to activate the Backlight.

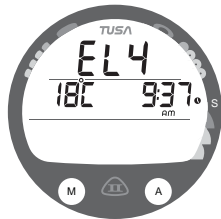

Fig. 77 - GAUG SURF ALT

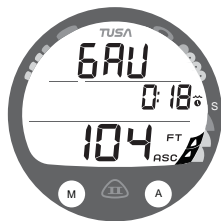

Fig. 78 - GAUG DIVE MAIN

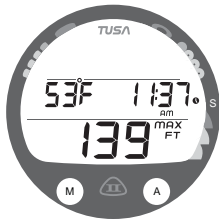

Fig. 79 - GAUG DIVE ALT

Gauge Dive ALT, information includes (Fig. 79) -

- > Temperature with degrees icon and graphic F (or C)
- > Time of Day (hr:min) with clock and AM (or PM) icons
- > Max Depth with FT (or M) and MAX icons

- The display will revert to the MAIN screen after 5 seconds or if the A button is pressed.
- Depress the S button for 2 seconds to activate the Backlight.

If you descend deeper than 330 FT (99.9 M), a cautionary mode referred to as Delayed Violation 3 will be activated.

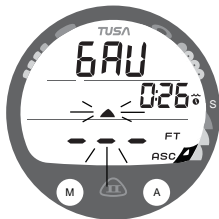

Fig. 80 - GAUG DV3 MAIN

DV3 Main, information includes (Fig. 80) -

- > Graphic GAU
- > EDT (hr:min) with wave/clock icon
- > Up Arrow icon (flashing)
- > Current Depth as 3 dashes (- - -) flashing with FT (or M) icon
- > ASC - if ascending

- Press and release the S button momentarily (< 2 sec) to acknowledge/silence Alarms.
- Press and release the A button momentarily (< 2 sec) to access the ALT screen, same as Fig. 79 with Max Depth as 3 dashes.
- Depress the S button for 2 seconds to activate the Backlight.

FREE DIVE OPERATING MODE

FREE DIVE MODE

When Free Dive Mode is selected as the operating mode, the Element II will operate with select features. Nitrogen loading is calculated based on a default FO2 of Air and the amount remaining during 24 hours is carried over between FREE and NORM modes.

- To access Free Dive Operating mode while viewing the Gauge Surface Main screen (no Gauge dive was made), press the M button 1 time for 2 seconds.
- The graphic FRE will flash indicating that it can be selected as the operating mode.
- To select it, press and release the M button momentarily (< 2 sec). The graphic becomes solid and Free mode is selected for the dives to be conducted.

NORM SURF >> GAUG SURF >> FREE SURF

Free Surface Main, information includes (Fig. 81) -

- > Graphic FRE
- > Graphic **tot** with Total number of repetitive Free dives conducted in that series with # icon (below)
- > Surface Interval after the most recent dive (min:sec to 59:59, then hr:min) with clock/wave icon (above next to FRE)
- > Battery icon if a Low Battery condition exists

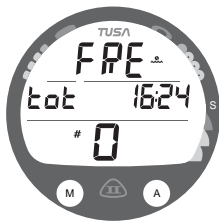

Fig. 81 - FREE SURF MAIN

- Press and release the A button momentarily (< 2 sec) to access the Free Surface ALT 1 screen, then again ALT 2.
- Depress the A button for 2 seconds to access the FREE CDT (Count Down Timer) Status screen.

- Depress the A and S buttons simultaneously for 2 seconds to access the Set Free EDT (Elapsed Dive Time) Alarm, then Set Free Depth Alarms 1, 2, 3.
- Depress the S button for 2 seconds to activate the Backlight.

Free Surface ALT 1, information includes (Fig. 82) -

- > Surface Interval prior to the last dive conducted (min:sec) with clock/wave icons
- > Graphic LAST (meaning most recent dive conducted)
- > Elapsed Dive Time (min:sec) of the last dive conducted with wave/clock icons
- > Max Depth of the last dive conducted with MAX and FT (or M) icons

- Press and release the A button momentarily (< 2 sec) to access the Free Surface ALT 2 screen.
- > The display will revert to the Main after 5 seconds if the A button is not pressed.
- Depress the S button for 2 seconds to activate the Backlight.

Free Surface ALT 2, information includes (Fig. 83) -

- > Altitude graphic (EL2 to EL7), if above 3000 feet (915 meters), blank if below.
- > Temperature with degrees icon and graphic F (or C)
- > Time of Day with clock and AM (or PM) icons



Fig. 82 - FREE SURF ALT 1

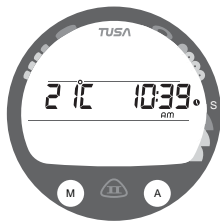

Fig. 83 - FREE SURF ALT 2

- > The display will revert to the Main after 5 seconds or if the A button is pressed/released.
- Depress the S button for 2 seconds to activate the Backlight.

FREE MODE COUNTDOWN TIMER (CDT)

After accessing the Free CDT Status screen from the Free Surface Main screen, the CDT can be started, stopped, and set.

Displayed are the graphics CDT and ON if running with Countdown Time (hr:min) remaining, or OFF flashing and the previously Countdown Time set, or OFF (solid) and 0:00 if no time was previously set (Fig. 84).

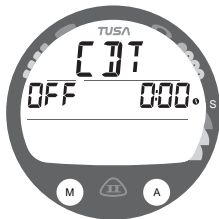

Fig. 84 - CDT STATUS
(Off, not set)

- Pressing and releasing the S button momentarily (< 2 sec) will toggle between ON and OFF. A toggle to ON will Start the CDT if a Time has been set.
- Depressing the A and S buttons simultaneously for 2 seconds will access Set Free CDT.
- Pressing and releasing the S button momentarily (< 2 sec) will revert to the Free Surface Main screen.
- If the M button is pressed for 2 seconds or if no button is pressed during a period of 2 minutes, operation will revert to the Free Surface Main screen.
- Depressing the S button for 2 seconds will activate the Backlight.

Once the CDT has been Set and Started (by selecting ON), it will continue to run in the background while on the surface until turned OFF (stopped) or the Time reaches 0:00 at which time the Alarm will strike, the graphic CDT will be displayed, and the Timer will revert to OFF.

When a set Countdown Time reaches 0:00, the Audible Alarm will sound during which the graphic CDT will flash (Fig. 85).

Upon descending to 5 FT/1.5 M (i.e., entry into Free Dive mode), CDT operation will continue, if in progress.

During a dive, the CDT can be turned OFF (stopped) and ON (started), but not Set.

Set Free CDT

Upon access, the Set CDT screen displays the graphics CDT and SEt and the CDT (min:sec) with clock icon, the Minute Set Point flashing (Fig. 86).

- Depressing the S button will scroll upward through the Minute Set Points in 1 minute increments at a rate of 8 per second.
- Pressing and releasing the S button momentarily and repeatedly (< 2 sec each time) will step upward through the Set Points one at a time.



Fig. 85 - CDT ALARM
(during audible)

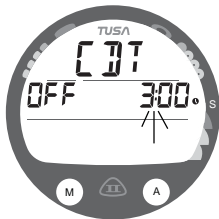

Fig. 86 - SET CDT



Fig. 87 - CDT SET
(ready to start)

- Pressing and releasing the A button momentarily (< 2 sec) will save the Minute Set Point and the Seconds digits will flash.
- Depressing the S button will scroll upward through the Seconds Set Points in 1 second increments at a rate of 8 per second.
- Pressing and releasing the A button momentarily (< 2 sec) will save the Seconds Set Point and revert to the CDT Status screen with the graphic OFF (flashing) in place of the graphic SET (Fig. 87).
- Pressing and releasing the S button momentarily (< 2 sec) will toggle from OFF to ON and Start the Timer.
- Depressing the M button for 2 seconds, or if no button is pressed during a period of 2 minutes, operation will revert to the Free Surface Main screen.

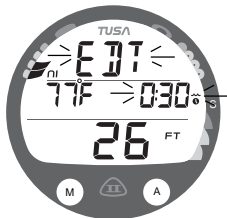

Fig. 88 - FREE EDT ALARM
(during dives)

FREE DIVE EDT (ELAPSED DIVE TIME) ALARM

The Free EDT Alarm is factory set for 30 seconds. When set ON, the Alarm will sound 3 short beeps and the graphic EDT and Time digits will flash every 30 seconds (Fig. 88).

- Depress the A and S buttons simultaneously for 2 seconds, while the Free Surface Main screen is displayed, to access Set Free EDT Alarm.

△ NOTE: The FREE EDT Alarm can only be Set (turned OFF or ON) while on the Surface and can not be changed during a Dive.

Set Free EDT Alarm, information includes (Fig. 89) -

- > Graphics EDT, 30 with clock icon, and SEC
 - > Set Point OFF (or ON) flashing.
- Pressing and releasing the S button momentarily (< 2 sec) will toggle the Set Point between OFF and ON.
 - Pressing the A button momentarily (< 2 sec) will accept the setting and access Set Free Depth Alarm 1.
 - Depressing the M button for 2 seconds, or if no button is pressed during a period of 2 minutes, operation will revert to the Free Surface Main screen.

FREE DIVE DEPTH ALARMS (DA)

Free Dive mode features 3 Depth Alarms (DAs) that can be Set at progressively deeper Depths and turned OFF/ON.

- > If Alarm 1 is set OFF, then Alarms 2 and 3 will be disabled.
- > If Alarm 2 is set OFF, Alarm 3 will be disabled.

When each alarm Depth set is reached during a dive, 3 short beeps will sound 3 times and the graphic DA1 (DA2, DA3) and Depth digits will flash (Fig. 90).

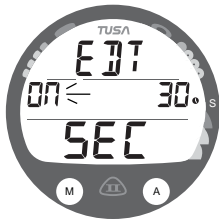

Fig. 89 - SET EDT ALARM

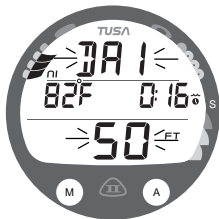

Fig. 90 - FREE DA ALARM
(DA 2, 3 similar)

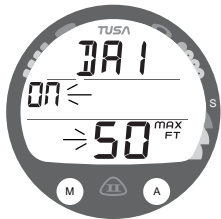

Fig. 91 - SET FREE DA 1

- Press and release the A button momentarily (< 2 sec) while viewing the Set Free EDT Alarm screen to access Set Free DA1 (Depth Alarm 1) screen. DA2 and DA3 are similar.

Set Free DA1, information includes (Fig. 91) -

- > Graphic DA1
- > Set Point OFF (or ON) flashing
- > Depth Set Point digits flashing if ON is selected, with MAX and FT (or M) icons

- Pressing and releasing the S button momentarily (< 2 sec) will toggle the Set Point between OFF and ON.
- Pressing and releasing the A button momentarily (< 2 sec) will accept the ON/OFF setting, and if OFF is selected operation will revert to the Free Surface Main screen, or if ON is selected the Depth digits will flash allowing them to be set.
- Depressing and holding the S button will scroll upward through the Depth Set Points from 30 to 330 FT (10 to 100 M) in increments of 10 FT (1 M) at a rate of 8 Set Points per second until it is released.
- Pressing and releasing the S button momentarily and repeatedly (< 2 sec each time) will step upward through the Set Points one at a time.
- Pressing and releasing the A button momentarily (< 2 sec) will accept the setting, and access Set DA2 (or DA3); or after setting DA3, operation will revert to the Free Surface Main screen.
- Depressing the M button for 2 seconds, or if no button is pressed during a period of 2 minutes, operation will revert to the Free Surface Main screen.

Free Dive Main, information includes (Fig. 92) -

- > NiBG, if any Nitrogen remaining from NORM or FREE dives conducted within the previous 24 hours
 - > NDC Time (min:sec) with wave/clock/profile icons
 - > Temperature with degrees icon and graphic F (or C)
 - > Elapsed Dive Time (min:sec) with wave/clock icons
 - > Current Depth with FT (or M) icon
- Press and release the A button momentarily (< 2 sec) to access ALT 1 (Free CDT Status).
 - Depress the S button for 2 seconds to activate the Backlight.



Fig. 92 - FREE DIVE MAIN

Free Dive ALT 1 (CDT), information includes (Fig. 93) -

- > Graphics CDT, and ON (or OFF) flashing
 - > CD Time (min:sec) with the colon flashing and clock icon, if ON and a CD is in progress; OFF and 0:00 with the colon flashing if it was running and no time remains. If OFF, the CD Time previously set will be displayed with the colon solid, indicating that it is set and ready to Start.
- Press and release the S button momentarily (< 2 sec) to toggle On/Off (Start/Stop).
 - Press and release the A button momentarily (< 2 sec) to access ALT 2.
 - Depress the S button for 2 seconds to activate the Backlight.



Fig. 93 - FREE DIVE ALT 1
(CDT in progress)

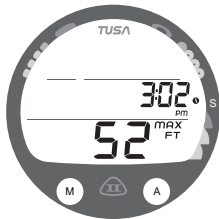

Fig. 94 - FREE DIVE ALT 2

- If no button is pressed during a period of 10 seconds, operation will revert to the Main.

Free Dive ALT 2, information includes (Fig. 94) -

- > Time of Day with clock and AM (or PM) icons
- > Max Depth with MAX and FT (or M) icons
- > The display will revert to the Main after 5 seconds or if the A button is pressed/released.
- Depress the S button for 2 seconds to activate the Backlight.

FREE DIVE ALARMS

Free Dive alarms sound 3 short beeps (1 or 3 times) as an indication that an event is occurring and as a reminder to view the display to identify an event. As the audible sounds, a graphic identifying the event will flash in place of NDC Time.

Free Dive alarms are separate and unaffected by NORM/GAUG mode alarm settings, and the Alarms that occur in those modes are separate and unaffected by Free Dive alarms.

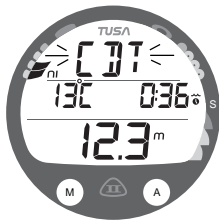

Fig. 95 - FREE CDT ALARM

Free CDT Alarm

When the Free CDT decreases to 0:00 (min:sec), 3 short beeps will sound 3 times during which the graphic CDT will flash (Fig. 95), then NDC will be restored.

Free Depth Alarms

When Depth reaches the Free Depth Alarm 1 Set Point, 3 short beeps will sound 3 times during which the graphic DA1 will flash (Fig. 96), then NDC will be restored.

The audible and flashing graphic will be repeated when Depth reaches the DA 2 and DA 3 Set Points, if set On.

If Ascent is made above a Free Depth Alarm Set Point and then a descent is made below it, the respective Alarm (DA) will reset and sound again.

Free EDT Alarm

When the Free EDT Alarm is set On, 3 short beeps will sound during which the graphic EDT will flash (Fig. 97), then NDC will be restored.

The Free EDT Alarm is factory set to repeat every 30 seconds, when it is set On prior to the dive.

Free NiBG Alarm

While operating in Free Dive mode, residual Nitrogen remaining from the Free Dives and any previous NORM SCUBA Dives conducted within 24 hours is displayed as the NiBG.

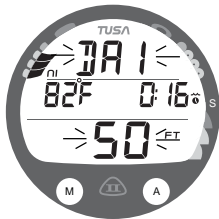

Fig. 96 - FREE DEPTH AL 1
(DA2 & DA3 similar)

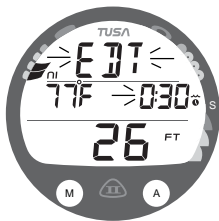

Fig. 97 - FREE EDT ALARM

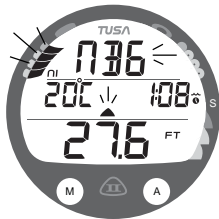

Fig. 98 - FREE NiBG ALARM

When Nitrogen loading increases to the Caution level, 3 short beeps will sound 3 times; and 4 NiBG No Deco segments, the Up Arrow icon, and the graphic NBG (in place of NDC) will be displayed (flashing) (Fig. 98).

After the beeps, the flashing will continue until the NiBG recedes to 3 segments at which time the NDC will be restored and the Up Arrow icon will be removed.

In the event that Nitrogen loading increases to the Deco level, operation will enter Violation Gauge Mode for 24 hours.

Entry into Deco (Violation)

Upon entry into Deco, 3 short beeps will sound 3 times, the full NiBG and full O2BG will be displayed with all segments flashing, and the graphic VIO will be displayed flashing (Fig. 99).

Upon surfacing, the Up Arrow icon will be removed, then after 10 minutes the NiBG and O2BG will be removed.

The graphic VIO will then alternate with FRE for 24 hours during which operation will lock into Violation Gauge Mode. Access to NORM or GAUG modes will be blocked.

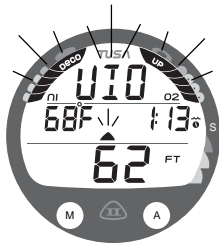

Fig. 99 - FREE DIVE DECO
(Violation)

ADDITIONAL INFORMATION PERTAINING TO FREE DIVE MODE

Although breathing apparatus is not utilized for Free Dive activities, nitrogen tissue loading remains a factor. Nitrogen loading is calculated based upon a fixed FO₂ of AIR. Since a user has the option of alternating between NORM (SCUBA) and Free Dive activities within a 24 hour period, nitrogen calculations and the displayed value of NDC Time are carried over from one operating mode to the other, which permits the user to maintain awareness of nitrogen absorption and off gassing status.

The mathematical model currently used in the Element II is based on no decompression/decompression multilevel repetitive dive schedules. This algorithm does not take into account the physiological changes associated with the high pressures that competitive type Free diving can expose a diver to.

WARNINGS:

- **Ensure that you know which Operating Mode is selected (NORM, GAUG, or FREE) prior to commencing any dive.**
- **Conducting Free dives within a 24 hour period after conducting SCUBA dives, combined with the effects of multiple rapid Free Dive ascents, increases your risk of decompression sickness. Such activities may result in accelerated entry into decompression which could cause serious injury or death.**
- **Combining competitive type Free dive activities that involve multiple descents/ascents with activities utilizing SCUBA during the same 24 hour period is not recommended. Presently, there is no data relating to such activities.**
- **It is highly recommended that anyone planning to become involved in competitive type Free Dive activities obtain proper instruction and training from a recognized Free Diving trainer. It is imperative that the physiological affects be understood and the diver is physically prepared.**

RESPONSIBLE COMPUTER DIVING

- **Plan each dive, and dive your plan.** The Element II was not designed to make decisions for you, only to provide you with the information you need to make responsible decisions for yourself. This begins with a dive Plan that will help you avoid a low air or decompression situation.
- **Do not plan any dive that exceeds your training or experience level.**
- **Inspect your Element II before every dive.** If it shows any signs of damage or abnormal function, **DO NOT** dive with it until it has received factory prescribed service.
- **Make a Safety Stop at 15 to 20 FT (4.5 to 6 M) at the end of every dive.** It's important, don't forget it.
- **You should make every effort to complete all of your ascents with the Nitrogen Bar Graph inside the normal No Decompression zone.**
- **If you inadvertently entered Decompression, you should not complete your ascent until the Nitrogen Bar Graph is at least inside the No Decompression Caution Zone.**
- **While you cannot provide a guarantee against the occurrence of decompression sickness, you may choose your own personal zone of caution based upon your individual age, physique, excessive weight, training, experience, etc. to reduce the statistical risk. By not pushing the limits, you can establish and adjust your personal level of conservatism and margin of safety.**

GENERAL

CARE AND CLEANING

Protect your Element II from shock, excessive temperatures, chemical attack, and tampering. Protect the lens against scratches with a transparent Instrument Lens Protector. Small scratches will naturally disappear underwater.

- Soak and rinse the Element II in fresh water at the end of each day of diving, and check to ensure that the areas around the low pressure (depth) sensor (Fig. 100a) and button are free of debris or obstructions.
- To dissolve salt crystals, use lukewarm water or a 50% white vinegar/50% fresh water bath. After removal from the bath, place the unit under gently running water and towel dry before storing.
- Transport your unit cool, dry, and protected.

INSPECTIONS AND SERVICE

Your Element II should be inspected annually by an Authorized TUSA Dealer who will perform a factory prescribed function check and inspection for damage or wear. To keep the product's warranty in effect, this inspection must be completed one year after purchase (+/- 30 days). TUSA recommends that you continue to have this inspection performed every year to ensure it is working properly.

To Obtain Service

Take your Element II to an Authorized TUSA Dealer.

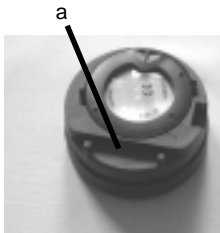

Fig. 100 - BACK OF CASE

△ NOTE: The procedures that follow must be closely adhered to. Damage due to improper battery replacement is not covered by the unit's warranty.

When the battery is removed, settings and calculations for repetitive dives will be retained in non volatile memory for subsequent operations.

MODULE REMOVAL FROM BOOT

If the Module is in a Console, bend the rubber Console Boot back to expose the edge of the Module. If the Boot is flexible enough to permit, you may bend it back far enough to scoop the Module out with your finger. Otherwise, it may be necessary to insert a blunt screwdriver until the tip rests just underneath the Module. **DO NOT** pry the Module from the Console! Slowly increase the pressure under the Module by releasing the tension on the rubber Boot. The Module will slide up the screwdriver and exit the Console.

If the Module is in a Wrist Boot, it will be necessary to peel the lips of the Boot downward off the Module while applying pressure from underneath, working it out slowly.

BATTERY REPLACEMENT

The Battery Compartment should only be opened in a dry and clean environment with extreme care taken to prevent the entrance of moisture or dust. To prevent formation of moisture in the Battery Compartment, it is recommended that the Battery be changed in an environment equivalent to the local outdoor temperature and humidity (e.g., do not change the Battery in an air conditioned environment, then take it outside during a hot sunny day).



Fig. 101 - RING REMOVAL

Battery Hatch Removal

- Locate the Battery Compartment on the back of the Module.
- While applying steady inward pressure on the center of the Battery Hatch, rotate the Hatch Retaining Ring 10 degrees clockwise using a flat blade screwdriver (Fig. 101) or a Battery Hatch Tool.
- Lift the Hatch Ring up and away from the Housing, or turn the Module over to allow it to drop out into your hand.
- Remove the Battery Hatch.

Battery Removal

- Remove the Retaining Bar located across the lower portion of the Battery (Fig. 102a).
- Remove the Hatch O-ring. DO NOT use tools
- Using care not to damage the Battery Contacts (Fig. 102b/c), slide the Battery up and out of the Battery Compartment.

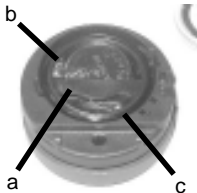

Fig. 102 - HATCH REMOVAL

Inspection

- Closely check all of the sealing surfaces for any signs of damage that might impair proper sealing.
- Inspect the Button, Lens, and Housing to ensure they are not cracked or damaged.

- If it is necessary to clean the Battery Compartment, flush it and all components with a solution of 50% white vinegar and 50% fresh water. Rinse with fresh water, and allow to dry overnight, or blow dry with a hair dryer set at no heat.



WARNING: If damage or corrosion is found, return your Element II to an Authorized TUSA Dealer, and DO NOT attempt to use it until it has received factory prescribed service.

Battery Installation

- Slide a new 3 volt type CR2450 Lithium Battery, negative (-) side down into the Battery Cavity. Slide it in from the right side and ensure that it slides under the contact clip on the left rim of the cavity (Fig. 103).
- Orient the Retaining Bar across the lower portion of the Battery and carefully push it down into position (Fig. 104).

Battery Hatch and Hatch Retaining Ring Installation

- Replace the Hatch O-ring with a new one which must be a genuine TUSA part.
- Lightly lubricate the new Hatch O-ring with silicone grease and place it on the inner rim of the Battery Hatch (Fig. 105). Ensure that it is evenly seated.
- Slide the Hatch Retaining Ring, top portion first (small opening), onto your thumb.



Fig. 103 - INSERTING BATTERY



Fig. 104 - INSERTING RETAINING BAR



Fig. 105 - O-RING ON RIM OF HATCH



Fig. 106 -ENGAGING the
RETAINING RING TABS

- Carefully place the Battery Hatch (with O-ring) into position on the rim of the Battery Compartment, then press it evenly and completely down into place with your same thumb.
- Maintain the Battery Hatch securely in place and, using your other hand, slide the Retaining Ring down off your thumb and into position around the Battery Compartment.
- The tabs on the Retaining Ring fit down into the two slots located at the 2 and 8 o'clock positions.
- Using your fingers, turn the Ring counter clockwise 5 degrees until the tabs engage (Fig. 106), then tighten it 5 more degrees by turning it counter clockwise using the Battery Hatch Tool (Fig. 107).
- While tightening the Retaining Ring, exert continuous inward pressure on it until it is secured in the proper position. A small symbol located on the Ring should be aligned with the Locked symbol located on the Housing (Fig. 107a)

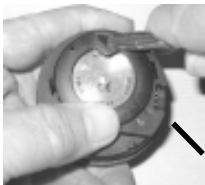

Fig. 107 -TIGHTENING the
RETAINING RING

Inspection

- Activate the unit and watch carefully as it performs a full diagnostic and battery check, and enters Surface Mode.
- Observe the LCD display to ensure it is consistently clear and sharp in contrast throughout the screen.



WARNING: If there are any portions of the display missing or appearing dim, or if a Low Battery condition is indicated, return the Element II to an Authorized TUSA Dealer for a complete evaluation before attempting to use it.

RETURNING THE MODULE TO BOOT

- If the Boot was fitted with a Spacer and it was previously removed, replace the Spacer into the Boot.
- Orient the Module over the opening in the Boot, and dip the bottom edge into it while pressing the top edge with the palm of your hand. Stop pressing when the bottom edge of the Module has just entered the Boot.
- Correct the alignment of the Module as needed so that it is straight.
- Press the Module completely into place with your thumbs, watching the alignment, until it snaps into place.

ALTITUDE SENSING AND ADJUSTMENT

Prior to the first dive of a series of repetitive dives, Altitude (i.e., Ambient Pressure) is measured upon activation and every 15 minutes until a dive is made.

- > While it is operating in Surface mode after a dive, measurements are taken every 15 minutes during the 24 hour period after surfacing.
- > Measurements are only taken when the unit is dry.
- > Two readings are taken, the second reading 5 seconds after the first. The readings must be within 1 foot (30 cm) of each other to record that ambient pressure as the current Altitude.

The mathematical model in the Element II accounts for the reduced No Deco Dive Times available based on National Oceanic and Atmospheric Administration (NOAA) guidelines.

When diving in high altitude waters from 3,001 to 14,000 feet (916 to 4,270 meters), the Element II automatically adjusts to these conditions providing corrected Depth, reduced No Deco Dive Times, and reduced Oxygen Accumulation Times at Altitude intervals of 1,000 feet (305 meters).

No adjustments are made during any time that the Wet Contacts are wet.

At an elevation of 3,001 feet (916 meters), Depth Calibration automatically changes from feet of seawater to feet of fresh water. This is the first adjustment to the Algorithm.

When the Conservative Factor feature is set ON, allowable dive times are calculated based upon the next higher 3,000 foot (915 meter) Altitude. All adjustments for Altitudes greater than 11,000 feet (3,355 meters) are then made to allowable dive times for 14,000 feet (4,270 meters). If the Conservative Factor is set ON while at Sea Level, calculations are based upon NDLs listed in the tables for the 5,001 to 6,000 foot (1,526 to 1,830 meter) range.

The Element II will not function as a Dive Computer above 14,000 feet (4,270 meters).

| PELAGIC Z+ ALGORITHM >> NDLs (HR:MIN) AT ALTITUDE (IMPERIAL) | | | | | | | | | | | | |
|--|-----------------|--------------------|--------------------|--------------------|--------------------|--------------------|--------------------|---------------------|----------------------|----------------------|----------------------|----------------------|
| Altitude (feet) | 0 to 3000 | 3001 to 4000 | 4001 to 5000 | 5001 to 6000 | 6001 to 7000 | 7001 to 8000 | 8001 to 9000 | 9001 to 10000 | 10001 to 11000 | 11001 to 12000 | 12001 to 13000 | 13001 to 14000 |
| Depth (FT) | | | | | | | | | | | | |
| 30 | 3:17 | 2:30 | 2:21 | 2:14 | 2:08 | 2:02 | 1:57 | 1:52 | 1:47 | 1:39 | 1:34 | 1:29 |
| 40 | 1:49 | 1:21 | 1:15 | 1:11 | 1:08 | 1:05 | 1:02 | 1:00 | 0:57 | 0:55 | 0:53 | 0:51 |
| 50 | 1:05 | 0:53 | 0:51 | 0:49 | 0:47 | 0:44 | 0:42 | 0:39 | 0:37 | 0:35 | 0:34 | 0:33 |
| 60 | 0:48 | 0:37 | 0:35 | 0:33 | 0:32 | 0:30 | 0:28 | 0:26 | 0:24 | 0:23 | 0:22 | 0:21 |
| 70 | 0:35 | 0:26 | 0:24 | 0:23 | 0:21 | 0:20 | 0:19 | 0:18 | 0:17 | 0:16 | 0:16 | 0:14 |
| 80 | 0:26 | 0:19 | 0:18 | 0:17 | 0:16 | 0:15 | 0:14 | 0:13 | 0:12 | 0:11 | 0:11 | 0:10 |
| 90 | 0:19 | 0:15 | 0:14 | 0:13 | 0:12 | 0:11 | 0:10 | 0:10 | 0:09 | 0:09 | 0:08 | 0:08 |
| 100 | 0:16 | 0:11 | 0:10 | 0:10 | 0:09 | 0:09 | 0:08 | 0:08 | 0:07 | 0:07 | 0:07 | 0:07 |
| 110 | 0:12 | 0:09 | 0:08 | 0:08 | 0:08 | 0:07 | 0:07 | 0:07 | 0:06 | 0:06 | 0:06 | 0:05 |
| 120 | 0:10 | 0:08 | 0:07 | 0:07 | 0:07 | 0:06 | 0:06 | 0:06 | 0:05 | 0:05 | 0:05 | 0:05 |
| 130 | 0:08 | 0:07 | 0:06 | 0:06 | 0:06 | 0:05 | 0:05 | 0:05 | 0:05 | 0:05 | 0:04 | 0:04 |
| 140 | 0:07 | 0:06 | 0:05 | 0:05 | 0:05 | 0:05 | 0:05 | 0:04 | 0:04 | 0:04 | 0:04 | 0:04 |
| 150 | 0:06 | 0:05 | 0:05 | 0:05 | 0:05 | 0:04 | 0:04 | 0:04 | 0:04 | 0:04 | 0:04 | 0:03 |
| 160 | 0:06 | 0:05 | 0:05 | 0:04 | 0:04 | 0:04 | 0:04 | 0:04 | 0:04 | 0:03 | 0:03 | 0:03 |
| 170 | 0:05 | 0:04 | 0:04 | 0:04 | 0:04 | 0:04 | 0:03 | 0:03 | 0:03 | 0:03 | 0:03 | 0:03 |
| 180 | 0:05 | 0:04 | 0:04 | 0:04 | 0:03 | 0:03 | 0:03 | 0:03 | 0:03 | 0:03 | 0:03 | 0:03 |
| 190 | 0:04 | 0:04 | 0:04 | 0:03 | 0:03 | 0:03 | 0:03 | 0:03 | 0:03 | 0:03 | 0:03 | 0:00 |

PELAGIC Z+ ALGORITHM >> NDLS (HR:MIN) AT ALTITUDE (METRIC)

| Altitude (meters) | 0 | 916 | 1221 | 1526 | 1831 | 2136 | 2441 | 2746 | 3051 | 3356 | | 3661 | 3966 |
|----------------------|------|------|------|------|------|------|------|------|------|------|------|------|------|
| | to | to | to | to | to | to | to | to | to | to | to | to | to |
| Depth (M) | 915 | 1220 | 1525 | 1830 | 2135 | 2440 | 2745 | 3050 | 3355 | 3660 | | 3965 | 4270 |
| 9 | 3:37 | 2:41 | 2:31 | 2:23 | 2:16 | 2:10 | 2:04 | 1:59 | 1:54 | 1:50 | 1:43 | 1:37 | |
| 12 | 1:55 | 1:27 | 1:21 | 1:15 | 1:12 | 1:08 | 1:05 | 1:03 | 1:00 | 0:58 | 0:55 | 0:54 | |
| 15 | 1:08 | 0:55 | 0:53 | 0:51 | 0:49 | 0:47 | 0:44 | 0:42 | 0:39 | 0:37 | 0:36 | 0:34 | |
| 18 | 0:50 | 0:39 | 0:37 | 0:35 | 0:33 | 0:32 | 0:30 | 0:28 | 0:26 | 0:24 | 0:23 | 0:22 | |
| 21 | 0:36 | 0:28 | 0:26 | 0:24 | 0:23 | 0:21 | 0:20 | 0:19 | 0:18 | 0:17 | 0:16 | 0:16 | |
| 24 | 0:27 | 0:20 | 0:19 | 0:18 | 0:17 | 0:16 | 0:15 | 0:14 | 0:13 | 0:12 | 0:11 | 0:11 | |
| 27 | 0:20 | 0:16 | 0:15 | 0:13 | 0:12 | 0:11 | 0:11 | 0:10 | 0:09 | 0:09 | 0:09 | 0:08 | |
| 30 | 0:16 | 0:12 | 0:11 | 0:10 | 0:09 | 0:09 | 0:09 | 0:08 | 0:08 | 0:07 | 0:07 | 0:07 | |
| 33 | 0:13 | 0:09 | 0:09 | 0:08 | 0:08 | 0:07 | 0:07 | 0:07 | 0:07 | 0:06 | 0:06 | 0:06 | |
| 36 | 0:10 | 0:08 | 0:07 | 0:07 | 0:07 | 0:06 | 0:06 | 0:06 | 0:05 | 0:05 | 0:05 | 0:05 | |
| 39 | 0:09 | 0:07 | 0:06 | 0:06 | 0:06 | 0:06 | 0:05 | 0:05 | 0:05 | 0:05 | 0:05 | 0:04 | |
| 42 | 0:08 | 0:06 | 0:06 | 0:05 | 0:05 | 0:05 | 0:05 | 0:05 | 0:04 | 0:04 | 0:04 | 0:04 | |
| 45 | 0:06 | 0:05 | 0:05 | 0:05 | 0:05 | 0:04 | 0:04 | 0:04 | 0:04 | 0:04 | 0:04 | 0:04 | |
| 48 | 0:06 | 0:05 | 0:05 | 0:04 | 0:04 | 0:04 | 0:04 | 0:04 | 0:04 | 0:03 | 0:03 | 0:03 | |
| 51 | 0:05 | 0:04 | 0:04 | 0:04 | 0:04 | 0:04 | 0:04 | 0:03 | 0:03 | 0:03 | 0:03 | 0:03 | |
| 54 | 0:05 | 0:04 | 0:04 | 0:04 | 0:04 | 0:03 | 0:03 | 0:03 | 0:03 | 0:03 | 0:03 | 0:03 | |
| 57 | 0:05 | 0:04 | 0:04 | 0:03 | 0:03 | 0:03 | 0:03 | 0:03 | 0:03 | 0:03 | 0:03 | 0:03 | |

**OXYGEN EXPOSURE LIMITS
(from NOAA Diving Manual)**

| PO2 (ATA) | Max Duration Single Exposure | | Max Total Duration 24 Hour Day | |
|--------------|---------------------------------|------|-----------------------------------|------|
| | (min) | (hr) | (min) | (hr) |
| 0.60 | 720 | 12.0 | 720 | 12.0 |
| 0.70 | 570 | 9.5 | 570 | 9.5 |
| 0.80 | 450 | 7.5 | 450 | 7.5 |
| 0.90 | 360 | 6.0 | 360 | 6.0 |
| 1.00 | 300 | 5.0 | 300 | 5.0 |
| 1.10 | 240 | 4.0 | 270 | 4.5 |
| 1.20 | 210 | 3.5 | 240 | 4.0 |
| 1.30 | 180 | 3.0 | 210 | 3.5 |
| 1.40 | 150 | 2.5 | 180 | 3.0 |
| 1.50 | 120 | 2.0 | 180 | 3.0 |
| 1.60 | 45 | .75 | 150 | 2.0 |

SPECIFICATIONS

CAN BE USED AS

- Air Computer
- Nitrox Computer
- Digital Depth Gauge/Timer
- Free Dive Depth Gauge/Timer

DIVE COMPUTER PERFORMANCE

- Buhlmann ZHL-16c based Pelagic Z+ algorithm
- No Deco limits closely follow PADI RDP
- Decompression in agreement with Buhlmann ZHL-16c and French MN90
- No Deco Deep Stops - Morroni, Bennett
- Deco Stops (not recommended) - Blatteau, Gerth, Gutvik
- Altitude - Buhlmann, IANTD, RDP (Cross)
- Altitude corrections and O2 limits based on NOAA tables

SURFACE SEQUENCE/MODES

- NORM > GAUG > FREE Surface Main
- SURF ALT (Altitude, Temp, Time)
- Plan (30 to 190 FT, 9 to 57 M) - NORM only
- Time to Fly - NORM/GAUG
- Time to Desaturate - NORM only
- Dive Log > History - NORM/GAUG
- Set > FO2, Alarms, Utilities, Time - NORM/GAUG

NORM/GAUG SET MODES

- Set F Group (FO2 items):
 - FO2 GAS1 (Air, 21 to 50%)
 - FO2 GAS2 (Air, 21 to 100%)
 - FO2 Default (On/Off)
- Set A Group (Alarms):
 - Audible/LED Warning (On/Off)
 - Max Depth (30 to 330 FT, 10 to 100 M)
 - Elapsed Dive Time (:10 to 3:00 hr:min)
 - NiBG (1 to 5 segments)
 - Dive Time Remaining (:00 to :20 min)
 - PO2 (1.20 to 1.60 ATA)
- Set U Group (Utilities):
 - Wet Activation (On/Off)
 - Units of Measure (Imperial/Metric)
 - No Deco Deep Stop (On/Off)
 - No Deco Safety Stop (On/Off)
 - Conservative Factor (On/Off)
 - Backlight Duration (0, 5, 10 seconds)
 - Sampling Rate (2, 15, 30, 60 seconds)
- Set T Group (Time/Date):
 - Date Format (Month.Day, Day.Month)
 - Time Format (12/24 Hour)
 - Time (hr:min)
 - Date (Year, Month, Day)
- Serial Number
 - > Factory set

SPECIFICATIONS (CONTINUED)

NUMERIC DISPLAYS:

| | Range: | Resolution: |
|-------------------------------|--|---------------|
| • Dive Number | 0 to 24 | 1 |
| • Current Depth | 0 to 399 FT (120 M) | 1 FT (.1/1 M) |
| • Maximum Depth | 399 FT (120 M) | 1 FT (.1/1 M) |
| • Gas 1 FO2 Set Point | Air, 21 to 50 % | 1 % |
| • Gas 2 FO2 Set Point | Air, 21 to 100 % | 1 % |
| • PO2 Value | 0.00 to 5.00 ATA | .01 ATA |
| • Dive Time Remaining | 0:00 to 9:59 hr:min | 1 minute |
| • No Deco Deep Stop Time | 2:00 to 0:00 min:sec | 1 second |
| • No Deco Safety Stop Time | 3:00 to 0:00 min:sec | 1 second |
| • Deco Stop Time | 0:00 to 9:59 hr:min | 1 minute |
| • Deco Total Ascent Time | 0:00 to 9:59 hr:min | 1 minute |
| • Norm/Gaug Elapsed Dive Time | 0:00 to 9:59 hr:min | 1 minute |
| • Free Elapsed Dive Time | 0:00 to 59:59 min:sec | 1 second |
| • Surface Interval Time | 0:00 to 23:59 hr:min | 1 minute |
| • Free Surface Interval Time | 0:00 to 59:59 min:sec | 1 second |
| | 1:00 to 23:59 hr:min | 1 minute |
| • Dive Log Surface Interval | 0:00 to 23:59 hr:min | 1 minute |
| • Time to Fly | 23:50 to 0:00 hr:min* | 1 minute |
| | (* starting 10 min after the dive) | |
| • Time to Desaturate | 23:50 max to 0:00 hr:min* | 1 minute |
| | (* starting 10 min. after the dive) | |
| • Temperature | 0 to 140°F (-9 to 60°C) | 1° |
| • Time of Day | 0:00 to 23:59 hr:min | 1 minute |
| • Free Countdown Timer | 59:59 to 0:00 min:sec | 1 second |
| • Out of Range (- - -) | => 330 FT (99.9 M) | |
| • Violation Countdown Timer | 23:50 to 0:00 hr:min (after surfacing) | |

SPECIFICATIONS (CONTINUED)

BAR GRAPHS

Nitrogen Bar Graph

segments

- No Deco Normal zone 3
- No Deco Caution zone 1
- Decom Warning zone 1

Oxygen (O2) Bar Graph:

segments

- Normal zone 3
- Caution zone 1
- Danger zone 1

Ascent Rate Indicator:

60 FT (18 M) & Shallower

Deeper than 60 FT (18 M)

| | segments | FPM | MPM | segments | FPM | MPM |
|----------------------------|----------|---------|-----------|----------|---------|-----------|
| • Normal Zone | 0 | 0 - 10 | 0 - 3 | 0 | 0 - 20 | 0 - 6 |
| • Caution Zone | 1 | 11 - 25 | 3.5 - 7.5 | 1 | 21 - 50 | 6.5 - 15 |
| • Too Fast Zone (flashing) | 2 | 26 - 30 | 8 - 9 | 2 | 51 - 60 | 15.5 - 18 |
| | 3 (all) | > 30 | > 9 | 3 (all) | > 60 | > 18 |

OPERATIONAL PERFORMANCE

Function:

Accuracy:

- Depth $\pm 1\%$ of full scale
- Timers 1 second per day

Dive Counter:

- NORM/GAUG displays Dives #1 to 24, FREE displays #1 to 99 (0 if no dive made yet)
- Resets to Dive #1, upon diving (after 24 hours with no dives)

SPECIFICATIONS (CONTINUED)

NORM/GAUG Dive Log Mode:

- Stores 24 most recent NORM/GAUG dives in memory for viewing
- After 24 dives, adds 25th dive in memory and deletes the older dive

Altitude:

- Operational from sea level to 14,000 feet (4,270 meters) elevation
- Measures ambient pressure every 30 minutes in Watch Mode and when Dive Computer Mode is accessed, every 15 minutes while in NORM/GAUG/FREE Surface Modes.
- Does not measure ambient pressure when Wet.
- Compensates for Altitudes above sea level beginning at 3,001 feet (916 meters) elevation and every 1,000 feet (305 meters) higher.

Conservative Factor:

- Reduces NORM/FREE NDLS to those for the Altitude 3,000 feet (915 meters) higher.

Power:

- Battery (1) 3 vdc, CR2450, Lithium battery
- Replacement User replaceable (annual recommended)
- Use Life 1 year or 300 dive hours if (2) 1 hour dives per dive day

Battery Indicator:

- Warning - icon on solid at 2.75 volts, Battery change recommended
- Alarm - icon on flashing at 2.50 volts, change the Battery

Dive Computer Mode Activation:

- Manual - push button (recommended), required if Wet Activation is set OFF.
- Automatic - by immersion in water (if set ON)
- Cannot be manually activated deeper than 4 FT (1.2 M).
- Cannot operate at elevations higher than 14,000 feet (4,270 meters).

SPECIFICATIONS (CONTINUED)

Operating Temperature:

- Out of the water - between 20 °F and 140 °F (-6 and 60 °C).
- In the water - between 28 °F and 95 °F (-2 and 35 °C).
- At extremely low temperatures, the LCD may become sluggish, but this will not affect it's accuracy. If stored or transported in extremely low temperature areas (below freezing), you should warm the unit and its battery with body heat before diving.

Storage Temperature:

- Out of the water (in storage case) - between 14 °F and 158 °F (-8 and 70 °C).

PC requirements:

- IBM[®] or compatible, Personal Computer with Mouse, USB Port, CD drive, and printer
- Intel[®] Pentium 200 MHz or better microprocessor
- Microsoft[®] Windows[®] 98 Second Edition, ME, NT, 2000, XP, or Vista
- Super VGA card or compatible video graphics adaptor (256 color or greater) with a minimum 800 X 600 pixel screen area of display settings
- 20MB of available hard drive storage
- 16MB of available RAM

TUSA INTERNATIONAL CONTACTS

Tabata USA, Inc
2380 Mira Mar Avenue
Long Beach, CA 90815
Tel: 562-498-3708
Fax: 562-498-0415
www.tusa.com
info@tusa.com

Tabata Europe Corporation B.V.
Den Brielstraat 2 B, 1055 RV
Amsterdam, The Netherlands
Tel: 31-(0)20 68 15 955
Fax: 31-(0)20 68 24 527
www.tusa.nl
info@tusa.nl

Tabata Australia PTY Ltd.
4D James Ruse Business Park
Northmeade, NSW 2152 Australia
Tel: 61-(0) 2-9890-4555
Fax: 61-(0) 2-9890-5222
www.tusa.com.au
info@tabata.com.au

Tabata Co. Ltd. Japan
1-3-17 Higashikomagata, Sumida-ku
Tokyo, Japan 130-0005
Tel: 81-(0)3-3624-2816
Fax: 81-(0)3-3623-9902
www.tusa.net
info@tabata.co.jp

Tabata Taiwan Co. Ltd.
54-8 Hsutsogang, Nankang Vil.
Tayuan Hsiang, Tao Yuan Hsien
Taiwan R.O.C.
Tel: 886-(0)3-386-5100
Fax: 886-(0)3-386-5103
info@mail.tabata.com.tw

INSPECTION / SERVICE RECORD

Serial Number: _____

Firmware Revision: _____

Date of Purchase: _____

Purchased from: _____

Below to be filled in by the Authorized TUSA Dealer:

| Date | Service Performed | Dealer / Technician |
|------|-------------------|---------------------|
| | | |
| | | |
| | | |
| | | |
| | | |

TUSA QUALITY

Worldwide Contacts:

Tabata USA, Inc. www.tusa.com

Tabata Australia Party Ltd. www.tusa.com.au

Tabata Europe Corporation B.V. www.tusa.nl

Tabata Mfg. Co. Ltd. www.tusa.net

Tabata Co. Ltd. Japan. www.tusa.net

© 2002 Design, 2009. All rights reserved.

Doc. No. 12-2980-r01 (7/15/09)